

ANALYSIS AND DESIGN OF PUMP HOUSE

K. RAVALI (14E41D2002),
M.Tech, Structural Engineering,
SreeDattha Institute of Engineering &
Science, Sheriguda, R.R Dist.

Mr. T. MALYADRI, Associate Professor
Department of Civil Engineering,
SreeDattha Institute of Engineering &
Science, Sheriguda, R.R Dist.

ABSTRACT

Structural design is the primary aspect of civil engineering. The very basis of construction of any pump houses, residential house or dams, bridges, culverts, canals etc. is designing. Structural engineering has existed since humans first started to construct their own structures.

The foremost basic in structural engineering is the design of simple basic components and members of a pump house viz., Slabs, Beams, Columns, Wall and Footings. In order to design them, it is important to first obtain the general arrangement drawing of the particular structure that is, positioning of the particular pumps (control panel room, office room, battery room, store room, outlet pipe, suction and delivery pipes etc.) such that they serve their respective purpose and also suiting to the requirement and comfort of the inhabitants. Thereby depending on the suitability; plan layout of beams and the position of columns are fixed. Thereafter, the loads are calculated namely the dead loads, which depend on the unit weight of the materials used (concrete, brick) and the live loads, which according to the code IS: 875-1987 is around 2 kN/m^2 .

Once the loads are obtained, the component takes the load first i.e. the slabs can be designed. Designing of slabs depends upon whether it is a one-way or a two-way slab, the end conditions and the loading. From the slabs, the loads are transferred to the beam. The loads coming from the slabs onto the beam may be trapezoidal or triangular. Depending on this, the beam may be designed. Thereafter, the loads (mainly shear) from the beams are taken by the columns. For designing columns, it is necessary to know the moments they are subjected to. For this purpose, frame analysis is done by STAAD PRO SOFTWARE. After this, the designing of columns is taken up depending on end conditions, moments, eccentricity and if it is a short or slender column. Most of the

columns designed in this mini project were considered to be axially loaded with uniaxial bending. Column and Beam Results are taken from ARC BDS Software. Finally, the footings are designed based on the loading from the column and also the soil bearing capacity value for that particular area. Most importantly, the sections must be checked for all the four components with regard to strength and serviceability.

Overall, the concepts and procedures of designing the basic components of a pumping station are described. Apart from that, the GAD of the structure with regard to appropriate directions for the respective rooms, choosing position of beams and columns are also properly explained.

INTRODUCTION

Civil engineering is the oldest engineering among all the engineering branches. For the past two decades information technology has brought revolutionary changes in engineering, civil engineering in not exceptional. Many software's which are useful for civil engineering were developed such as Auto cad, Staad, Primavera etc. For analysis design, planning and detailing of the structures. In the contemporary engineering field it is necessary to have strong fundamental knowledge regarding the subject and relative software for economical and safe design of engineering structures.

Therefore, in the present study a Pumping station (RCC) structure have been analysed, designed and detailed manually and using software STAAD Pro, AUTOCAD and

MSXL. Plinth area of the structure is 302.575 m². Loads coming on to the structure were considered from IS 875:1987 and the structure was designed in accordance with IS 456: 2000.

The objectives of the present study include:

1. Finalized GAD plan and elevation of the structure
2. Design of structural elements manually
3. Analysis and design of structural elements using software: STAAD pro.
4. Detailing of structural elements.
5. Getting familiar with structural software (STAAD pro , Auto CAAD)
6. Getting real life experience with engineering practices.

PLANNING OF ROOMS IN PUMP HOUSE

For planning of the structure, there is a necessity of knowing the various rooms required by occupants. In the proposed, the various rooms in a plan provided are listed below.

- a) Control panel room.
- b) Office room.
- c) Battery room.
- d) Store room.
- e) Attached bathroom.

FOOTING:

The main purpose of the footing is effectively support the super structure (columns or walls) by transmitting the applied loads, moments and other forces the soil without exceeding the safe bearing capacity of soil and the settlement of the

structure should be within permissible limits.

TYPES OF FOOTINGS:

a) Isolated footing:

In ordinary structures located on reasonably firm soil, it usually suffices to provide a separate footing for every column. Such a footing is called an isolated footing. It is generally square or rectangular in plan. The footing basically comprises a thick slab which may be flat, stepped or sloped.

b) Combined footing:

A combined footing supports two or more columns in a row when the areas required for individual footings are such that they come very near each other. They are also preferred in situations of limited space on one side owing to the existence of boundary line of private property.

c) Strap footing:

A strap footing comprises two or more footings connected by a beam called strap. This is also called cantilever footing or pump-handle foundation. This may be required when the footing of an exterior column cannot extend into an adjoining private property.

d) Wall footings:

Reinforced concrete footings are required to support reinforced concrete walls, and are also sometimes employed to support load-bearing masonry walls. Wall footings distribute the load from the wall to a wider area, and are continuous throughout the length of the wall. The footing slab bends essentially in the direction transverse to the

wall, hence is reinforced mainly in the transverse direction with only distributors in the longitudinal direction.

COLUMNS:

Columns are structural elements used primarily to support compressive loads. They are usually square, rectangular, circular, L-shaped or octagonal in cross section it is reinforced with longitudinal and transverse steel. Longitudinal steel contributes to the load carrying capacity of the section and transverse steel provide lateral support to the longitudinal steel and confines the concrete.

Classification:

They can be classified as follows

Based on type of loading:

a) Axially loaded columns:

Interior columns of multistoried buildings with symmetrical loads from all sides are common and it is rarely obtained.

b) Columns with Uni-axial eccentric loading:

This type of loading generally encountered to beams from one side only such as the edge column.

c) Columns with Bi-axial eccentric loading:

This type of loading is common in corner of the column with beams rigidly collected at right angle

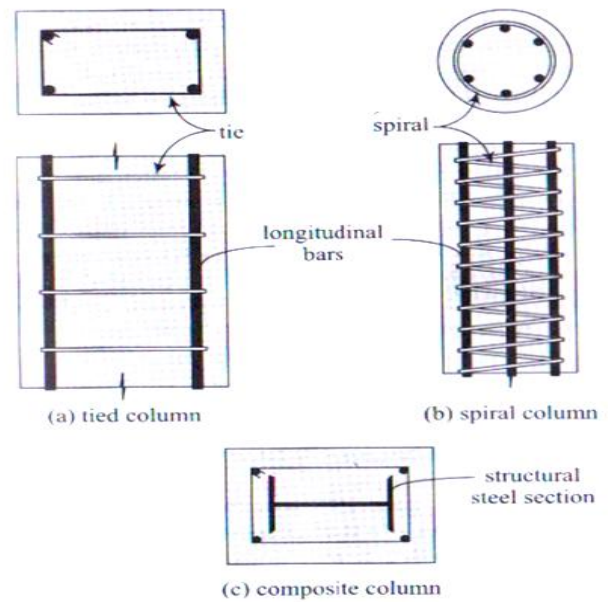

Fig: Types of columns based on the reinforcement.

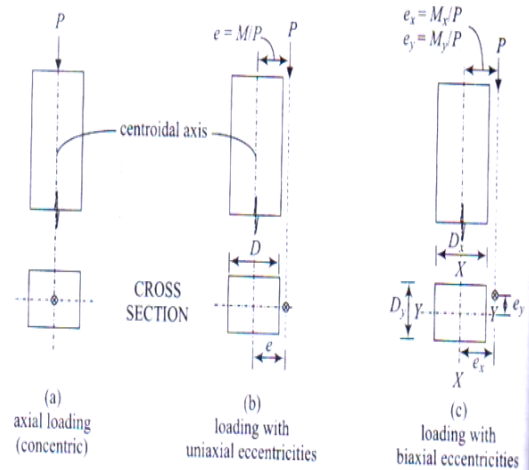

Fig : Types of columns based on loading.

STAIR CASE:

Stair cases are used in almost all buildings. A Stair cases consist of a number of steps arranged in a series, with landing at appropriate locations, for the purpose of giving access to different floors of a structure. The width of a stair cases may

depends on the purpose for which it is provided, and may generally vary between in residential building to 2 m for public buildings .A flight is the length of the stair cases situated between two landings. The number of steps in a flight may vary between 3 to 12.

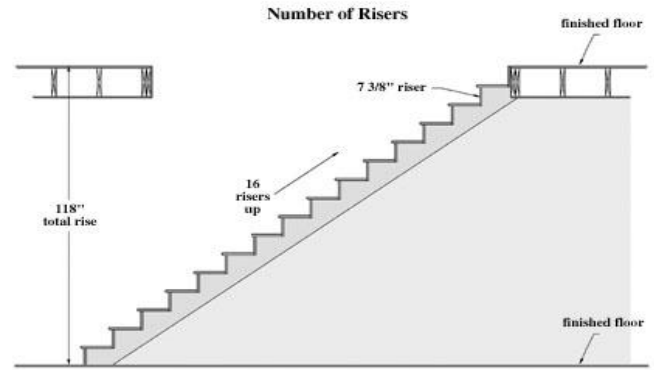

Fig: Stair cases

14.0 Pump House Roof Slab @ 243.500m Level							
(A)	One long edge discontinuous						
(B)	One short edge discontinuous						
(C)	Two Adjacent Edges discontinuous						
Data							
Minimum percentage of steel			0.12 %	As per clause 26.5.2.1 of IS: 456			
			(A)	(B)	(C)		
Grade of concrete			M 30	M 30	M 30		
Grade of steel			Fe 500	Fe 500	Fe 500		
Clear cover of slab			25	25	25	mm	
Thickness of the slab			150	150	150	mm	
Dia of main R/F bar			10	10	10	mm	
Eff. depth of slab			120	120	120	mm	
Unit weight of concrete			25	25	25	kN/m ³	
Load details							
Self weight of slab			3.75	3.75	3.75	kN/m ²	
Live Load on the slab			1.5	1.5	1.5	kN/m ²	
Total load, W			5.25	5.25	5.25	kN/m ²	
Factored load, Wu		(Factor)	1.5				

			=				
			7.875	7.875	7.875	kN/m ²	
Span details							
Clear span, x-axis			3.2	3.815	3.815	m	
Clear span, y-axis			3.815	4.2	5.93	m	
Width of beam			0.3	0.3	0.3	m	
Width of beam			0.3	0.3	0.3	m	
Effective thk. of slab			0.12	0.12	0.12	m	
Eff. Shorter Span, Lx			3.32	3.935	3.935	m	
Eff. Longer Span, Ly			3.935	4.32	6.05	m	
Longer span/Shorter span			Ly/Lx	Ly/Lx	Ly/Lx		
			1.19	1.1	1.54		
			Two-way	Two-way	Two-way		
Edge condition considered			Cond'n 2	Cond'n 3	Cond'n 4		
B.M Coefficients As per table-4 clause D-1.1 and 24.4.1 of IS: 456			One Short Edge Discontinuous	One Long Edge Discontinuou s	Two Adjacent Edges Discontinuou s		
Moment coefficients obtained	(+ve)	αx	0.036	0.033	0.057		
		αy	0.028	0.028	0.035		
	(-ve)	αx	0.048	0.044	0.076		
		αy	0.037	0.037	0.047		
Therefore, the bending moments are as follows,							
M_x = α_x W_u L_x²			M_y = α_y W_u L_x²				

AUTO CAD:

AutoCAD is a commercial computer-aided design (CAD) and drafting software application. AutoCAD is licensed, for free, to students, educators, and educational institutions, with an 36-month renewable license available. In this project 2015 version used. AutoCAD supported drawing of lines, circles, and other shapes; creation

of text and comment boxes; and management of color, layer, and measurements - in both landscape and portrait modes.

ARC BDS: (A Reinforced Concrete Beam Detailing Software)

The Nodes Data and Beam Connectivity data can be given in the

GUI(Graphic User Interface) of the program, and it will generate the layout and LS of the beams of the floor. The Data Extraction from STAAD ANL file is only to help the user populate the GUI part of the program (Nodes Data & Beam Data fields). It Gives Accurate BOQ of steel of all the beams.

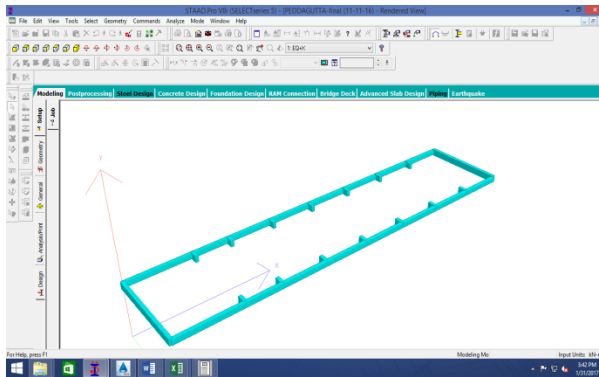

Fig No: 3D Rendered View Of Corbel Beam

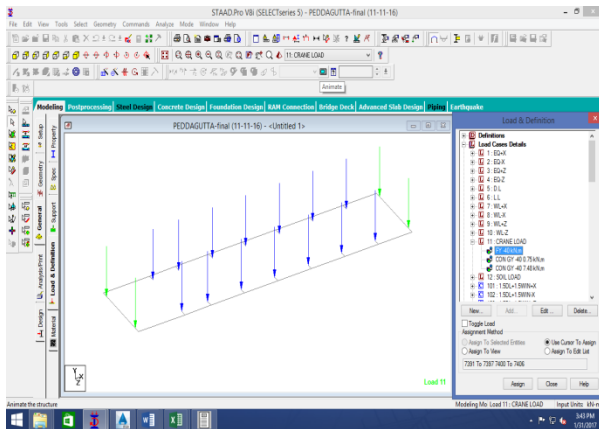

Fig No: Crane Loading On Corbel Beam

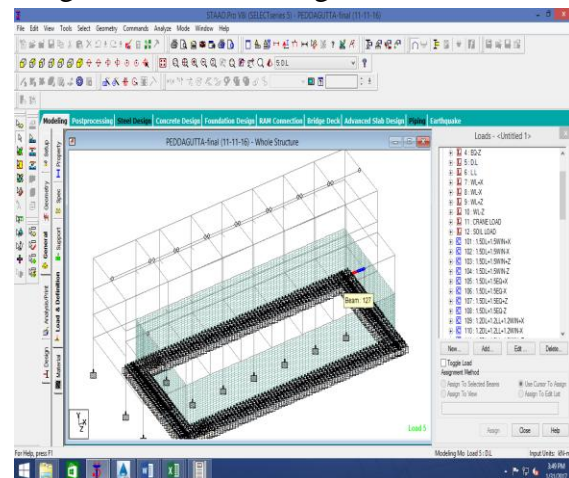

Fig No: Pump House Whole Structure

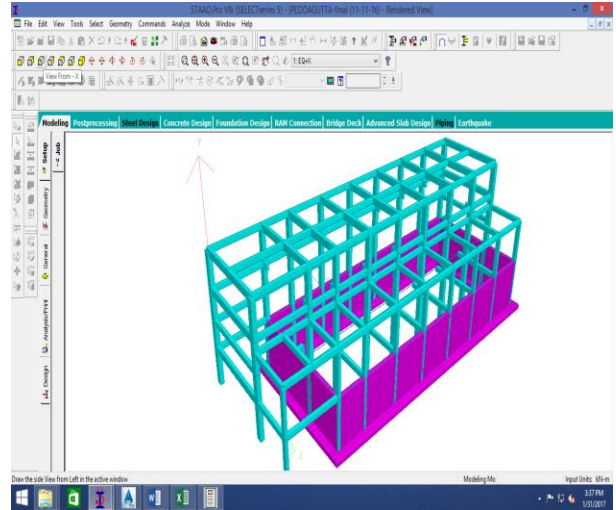

Fig No: Pump House-3D Rendered View

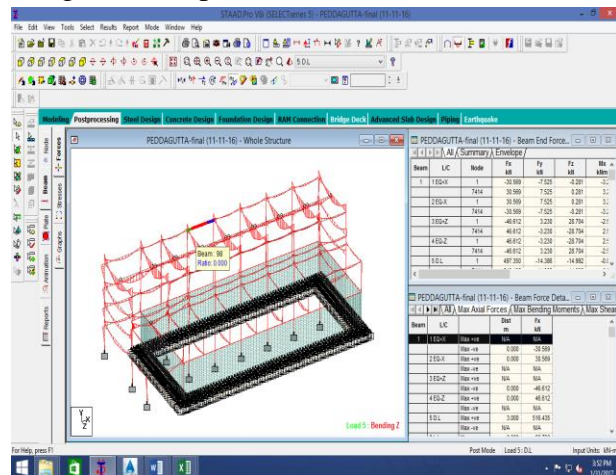

Fig No: Beam Bending Moment Diagram

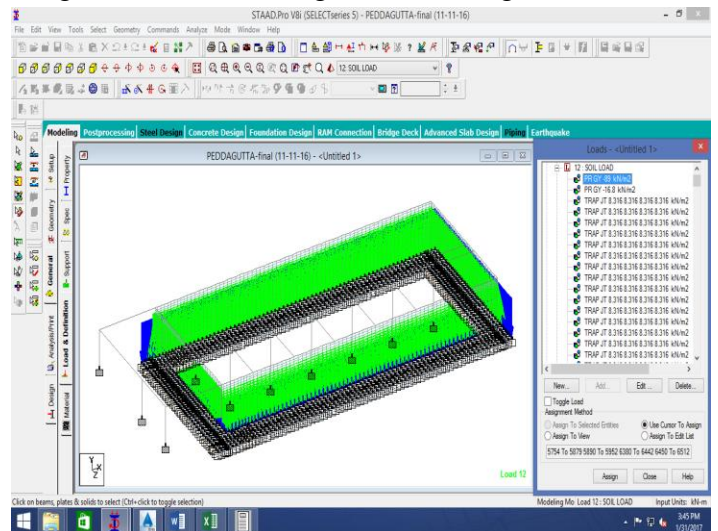

Fig No: Wall And Raft Loading

RESULTS

21.4 BASE PRESSURE CALCULATIONS FOR FOOTING: F4							
Footing Length along X -axis	Lx	=	1.60	m			
Footing Length along Z -axis	Lz	=	1.60	m			
Width of column	B	=	0.30	m			
Depth of Column	D	=	0.45	m			
Thickness of Footing	d	=	0.45	m			
Area of the Footing	A	=	(L x B)	=	2.56	m ²	
Sectional Modulus About X axis	Zx	=	(L x B ²)/6	=	0.68	m ³	
Sectional Modulus About Z axis	Zz	=	(B x L ²)/6	=	0.68	m ³	
Unit weight of soil		=	21	kN/m ³			
Unit weight of Concrete		=	25	kN/m ³			
	Pmax	=	(P/A)+(Mx/Zx)+(Mz/Zz)				
			181.82	KN/m ²			
	Pmin	=	(P/A)-(Mx/Zx)-(Mz/Zz)				
			31.89	KN/m ²			
	Allowable SBC	=	220	KN/m ²			
SUPPORT REACTIONS (P,MX,MZ) FROM STAAD							
JOINT	LOAD COMBINATION	P	Mx	Mz	Self Wt.	Pmax	Pmin
7416	201 1.0DL+1.0LL	220.98	5.4 7	12.603	28.8	124.05	71.10
	202 1.0DL+1.0WIN+X	205.62	5.4 2	12.861	28.8	118.34	64.79
	203 1.0DL+1.0WIN-X	207.94	5.5 1	12.449	28.8	118.79	66.16
	204 1.0DL+1.0WIN+Z	219.88	17. 3	13.474	28.8	142.16	52.12
	205 1.0DL+1.0WIN-Z	193.46	6.5 9	11.977	28.8	114.02	59.62
	206 1.0DL+1.0EQ+X	198.35	5.2 2	14.715	28.8	117.93	59.53
	207 1.0DL+1.0EQ-X	215.31	5.7 6	10.753	28.8	119.55	71.17

	208 1.0DL+1.0EQ+Z	239.98	31. 8	14.046	28.8	172.13	37.85
	209 1.0DL+1.0EQ-Z	173.69	20. 8	11.422	28.8	126.31	31.89
	210 1.0DL+1.0LL+1.0WIN+X	219.76	5.4	12.73	28.8	123.65	70.54
	211 1.0DL+1.0LL+1.0WIN-X	222.09	5.4 9	12.318	28.8	124.09	71.91
	212 1.0DL+1.0LL+1.0WIN+Z	234.03	17. 2	13.343	28.8	147.46	57.87
	213 1.0DL+1.0LL+1.0WIN-Z	207.61	6.6 1	11.846	28.8	119.38	65.31
	214 1.0DL+1.0LL+1.0EQ+X	212.5	5.2	14.584	28.8	123.24	65.28
	215 1.0DL+1.0LL+1.0EQ-X	229.46	5.7 4	10.622	28.8	124.85	76.91
	216 1.0DL+1.0LL+1.0EQ+Z	254.13	31. 8	13.915	28.8	177.44	43.60
	217 1.0DL+1.0LL+1.0EQ-Z	187.84	20. 8	11.291	28.8	131.67	37.58
	218 1.0DL+1.0LL+1.0CL+1.0EQ+X	212.62	4.9 7	14.647	28.8	123.05	65.56
	219 1.0DL+1.0LL+1.0CL+1.0EQ-X	229.58	5.5 2	10.685	28.8	124.66	77.20
	220 1.0DL+1.0LL+1.0CL+1.0EQ+Z	254.25	31. 5	13.978	28.8	177.25	43.88
	221 1.0DL+1.0LL+1.0CL+1.0EQ-Z	187.96	21. 1	11.355	28.8	132.14	37.20
	222 1.0DL+1.0LL+1.0SL+1.0EQ+X	218.36	4.9 5	16.258	28.8	127.62	65.48
	223 1.0DL+1.0LL+1.0SL+1.0EQ-X	235.33	5.4 9	12.296	28.8	129.23	77.12
	224 1.0DL+1.0LL+1.0SL+1.0EQ+Z	259.99	31. 5	15.589	28.8	181.82	43.80
	225 1.0DL+1.0LL+1.0SL+1.0EQ-Z	193.7	21. 1	12.966	28.8	136.78	37.05
	226 1.0DL+1.0LL+1.0SL+1.0CL	226.97	5	14.34	28.8	128.23	71.58
						181.82	77.20
						114.02	31.89
		259.99					

CONCLUSION

After doing this project work, we have learnt a lot of things and gained a good knowledge of the practical application which were not possible for us to learn in the class, as the practical application of what we learned in our engineering academic life is somewhat different from what is applied on the ground, based on the existing condition and surroundings. This project has not only taught us how to apply what we have learn but also how to work with the changing environment and condition of the site. During the tenure of the project, we also come across number of steps that can followed to make our work easier, such as making EXCEL spread sheets, small software &Staad pro, etc. to design the slabs, beams, columns, walls, Raft, footings, etc. easily. As the main theme of this project was not only learning or doing the project based on software only but to learn and develop the knowledge of manual designing also and at the same time to develop an idea to develop an idea of using the different civil engineering knowledge with available software packages such as MS Excel, VB, GML, etc. to ease our work our design procedure was accepted by our external and our internal guide as good piece of work, and we as a learn thanks them for their unconditional help and support in bringing out this project report.

REFERENCES

1. *R.C.C. DESIGNS (Reinforced concrete structures)*. Dr.B.C. Punmia.
2. Design of Reinforced Concrete Structures. S.Ramamrutham.

DhanpatRai Publishing Co. Pvt. Ltd.
Website : www.dhanpatrai.in

3. Design of Reinforced Concrete Structures. P.Dayaratnam. Oxford & IBH Publishing Co. Pvt. Ltd. New Delhi.
4. <http://www.zaxisis.com/downloads/AR-C-BDS%20Brochure.pdf>
5. <https://en.wikipedia.org/wiki/AutoCAD>
6. <http://www.autodesk.in/products/autocad/overview>