



## RECTIFICATION OF HARMONICS IN POWER SYSTEM BY EMPLOYING FUZZY BASED SVPWM TECHNIQUE

**A.SESHA SATYAPRASAD,**

M. Tech Student Deptt of of EEE (Power Electronics). Tudi Ram Reddy Institute of Technology & Sciences, Hyderabad.

**Email: [seshu22932@gmail.com](mailto:seshu22932@gmail.com)**

**MR.DURGAM.SRINIVAS,**

Assistant Professor, Department of EEE. Tudi Ram Reddy Institute of Technology & Sciences, Hyderabad.

**Email: [durgamsrinivas247@gmail.com](mailto:durgamsrinivas247@gmail.com)**

**ABSTRACT:** *In the recent decades, the world has seen an expansion in the use of non-linear loads. These loads draw harmonic non-sinusoidal currents and voltages in the connection point with the utility and distribute them through it. The propagation of these currents and voltages into the grid affect the power systems in addition to the other client's equipments. As a result, the power quality has become an important issue for both consumers and distributors of electrical power. Active power filters have been proposed as efficient tools for power quality improvement and reactive power compensation. In this work, harmonic problem is introduced and discussed. The different traditional and modern harmonic solutions topologies are presented. Shunt active power filter as the most famous and used active filter type is introduced. The use of SAPF for harmonic current and reactive power compensation is studied. Different control methods of APF in addition to different harmonic extraction methods are presented and discussed. Self Tuning Filter for the improvement of the SAPF's efficiency in the case of distorted and unbalance voltage system is presented and discussed. Different studied SAPF control strategies are implemented in MATLAB\Simulink and results are tabulated and discussed.*

**Keywords:** Active Power Filter, Instantaneous Power Theory, Self Tuning Filter, Harmonics, Non Linear Load.

### I. INTRODUCTION

Highly automatic electric equipments, in particular, cause enormous economic loss every year. Owing both power suppliers and power consumers are concerned about the power quality problems and compensation techniques. Power electronic converters act as sources of voltage or current harmonics, and if these are of a sufficient size, system voltage distortion and even grid stability problems can occur [2], [3]. Active power filters are grid connected power converters, which have been developed to mitigate the effects of

nonlinear loads. The shunt active filter (SAF) is one such device. It is designed to inject current harmonics [10] into the distribution grid, which exactly cancel the polluting currents caused by disturbing nonlinear loads [1], [4]. In recent years, single phase electronic equipments have been widely used in domestic, educational and commercial appliances. In other words, those equipments draw non-sinusoidal currents which pollute the utility line due to the current harmonics generated by the nonlinear loads [1]. It is noted that non-sinusoidal current results in many problems for the utility power supply company, such as: low power factor, low energy efficiency, electromagnetic interference (EMI), distortion of line voltage etc. Several control strategy like PI, PID and Fuzzy controller [9] are developed for shunt active filters.

The Problem with the PI and PID controller is that the response time will be very high and also the settling time is high, Total harmonic distortion is more, Power factor is low. Fuzzy controller has problems like redundancy, need of unique numbers for iteration. Though several control strategies[11] have been developed but still one control theory, space vector pulse width modulation methods are always dominant. The shunt active filter with voltage source inverter will have more Total Harmonic Distortion. This problem can be avoided by using Multi level inverters. In this paper seven level cascaded shunt active

filter is proposed. In the proposed system, Total harmonic Distortion is very low and Power Quality is improved. In this paper, an improved SVPWM based shunt APF topology is proposed. The harmonic currents are extracted by synchronous reference frame (SRF) theory and the switching instants for each inverter arm are computed directly using the effective time relocation algorithm. The DC bus voltage of the APF is stabilized with a traditional PI voltage feedback controller. And PI controller is replaced by fuzzy controller for improving the performance of SAPF. Simulation results in MATLAB/Simulink environment demonstrate the improvement in the performance of the proposed SVPWM based shunt APF.

**I. SHUNT APF TOPOLOGY**

The core part of the shunt APF is shown in Fig1. This topology consists of two-level VSI coupled with DC capacitor, which is connected in shunt to the nonlinear load at the Point of Common Coupling (PCC) through a ripple filter. Here,  $V_{sa}$ ,  $V_{sb}$ ,  $V_{sc}$  represent the source voltages. Load currents drawn by the nonlinear load are represented as  $i_{la}$ ,  $i_{lb}$ ,  $i_{lc}$ . Source currents and active filter currents are represented as  $i_{sa}$ ,  $i_{sb}$ ,  $i_{sc}$  and  $i_{fa}$ ,  $i_{fb}$ ,  $i_{fc}$  respectively. Capacitor C is the energy storage element on the dc side to maintain the dc bus voltage  $V_{dc}$  constant. The compensation signals are generated based on the improved SVPWM based controller

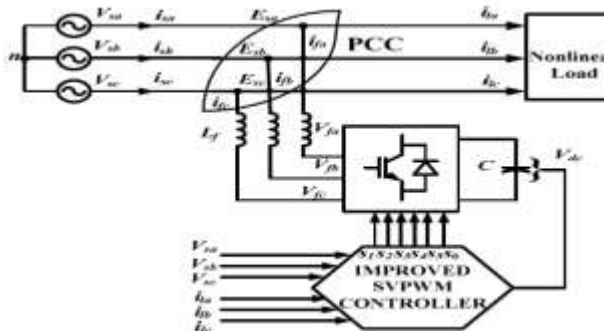

**Fig.1. Configuration of Improved**

**SVPWM based shunt APF.**

The compensation currents of the APF are given by

$$\begin{cases} i_{fa} = i_{la} - i_{sa} \\ i_{fb} = i_{lb} - i_{sb} \\ i_{fc} = i_{lc} - i_{sc} \end{cases} \quad (1)$$

The voltage-source PWM Inverter with a current controller should provide the ability of controlling the harmonic currents. The control circuit should extract the harmonic current from the nonlinear load, not only in steady states but also in transient states. As for three phase APFs, the instantaneous reactive power theory (IRPT) also called as p-q theory [1] or the synchronous reference frame (SRF) theory [6] are generally applied for estimation of the necessary compensation signals, and the PWM strategies for generation of gating signals. In the proposed shunt APF topology, SRF theory is used for harmonic current extraction and SVPWM technique is used to generate the switching signals. Furthermore, SVPWM does not require the triangle waveform generation circuit and is more suitable for realisation in digital control circuits. Here  $V_{sa}$  &  $i_{sa}$  are the phase-A source voltage and source current and  $R_s$  &  $L_s$  are the internal source resistance and inductance.  $E_{sa}$  is the instantaneous voltage of phase A at PCC.

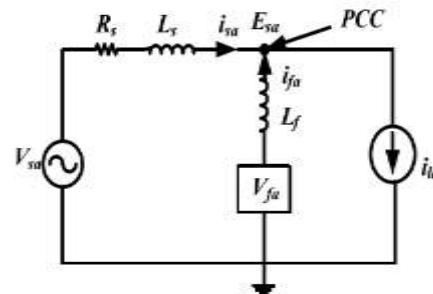

**Fig.2. Single-phase equivalent circuit of APF topology.**

$V_{fa}$ ,  $i_{fa}$  &  $L_f$  are the phase A APF voltage, current and inductance,  $i_{la}$  is

nonlinear load current. The above network can be described by the following equations in terms of APF voltage  $V_{fa}$  and current  $i_{fa}$ .

$$V_{fa} = L_f \frac{di_{fa}}{dt} + E_{sa} \tag{2}$$

Similarly

$$V_{fb} = L_f \frac{di_{fb}}{dt} + E_{sb}$$

$$V_{fc} = L_f \frac{di_{fc}}{dt} + E_{sc}$$

From the above equations the APF voltages in a-b-c frame can be written as

$$V_{f,abc} = L_f \frac{di_{f,abc}}{dt} + E_{s,abc}$$

The source current  $i_{s,abc}$  is forced to be free of harmonics by suitable voltages from the APF, and the harmonic current emitted from the load is then automatically compensated. The proposed APF is connected into the network through the inductor  $L_f$ . The function of  $L_f$  is to attenuate the high frequency switching ripple generated by APF and to connect two AC voltage sources of the inverter and the supply system.

## II. SYNCHRONOUS REFERENCE FRAME THEORY FOR HARMONIC EXTRACTION

In this work SRF is used for harmonic current extraction [6]. The block diagram of proposed shunt APF control scheme shown in Fig3. In order to maintain sinusoidal source currents with unity power factor at PCC, the source has to supply only the fundamental real component of load current.

Hence, the harmonics, reactive component of load current should be supplied from APF. Therefore, the load currents are sensed and transformed to dq0 reference frame as follows

$$V_{fd} = L_f \frac{di_{fd}}{dt} - \omega L_f i_{fq} + E_{sd}$$

$$V_{fq} = L_f \frac{di_{fq}}{dt} + \omega L_f i_{fd} + E_{sq}$$

$$V_{f0} = L_f \frac{di_{f0}}{dt} + E_{s0} \tag{8}$$

$$\begin{pmatrix} i_d \\ i_q \\ i_0 \end{pmatrix} = \sqrt{\frac{2}{3}} \begin{pmatrix} \cos\theta & \cos(\theta-2\pi/3) & \cos(\theta+2\pi/3) \\ \sin\theta & \sin(\theta-2\pi/3) & \sin(\theta+2\pi/3) \\ \frac{1}{\sqrt{2}} & \frac{1}{\sqrt{2}} & \frac{1}{\sqrt{2}} \end{pmatrix} \begin{pmatrix} i_a \\ i_b \\ i_c \end{pmatrix}$$

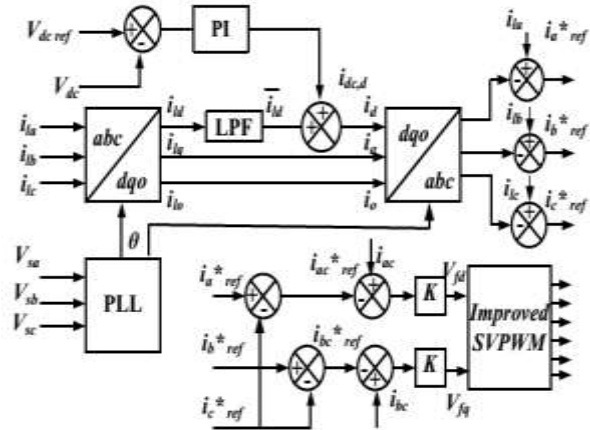

**Fig.3. Proposed SVPWM control for APF topology.**

The harmonic currents for each of the three phases are derived by removing the fundamental frequency component from load currents. Thus, the reference currents normally consist of harmonic components drawn by the load. A low pass filter (LPF), with cut off frequency of 50Hz is used to extract  $i_{ld}$ . Here,  $i_{ld}$  corresponds to harmonic load currents in a-b-c frame. The loss component of VSI is  $i_{dc,d}$  must be added to  $i_{ld}$  in order to acquire complete d-axis reference filter current. As  $i_q, i_0$  currents must be supplied directly, LPFs are not required in q-axis and 0-axis controller as shown in Fig3.

Therefore, the dq0 reference harmonic currents are given by

$$\begin{cases} i_d = i_{ld} + i_{dc,d} \\ i_q = i_{lq} \\ i_0 = i_{l0} \end{cases} \tag{7}$$

The dq0 transformation of (5) generates the following set of equations [6].

(9)

(10)

Where,  $V_{fd}$ ,  $V_{fq}$ ,  $V_{f0}$  are the variables to be controlled, in order to achieve the desired filter currents at PCC in  $dq0$  frame,  $\omega$  is the system frequency and  $if_d$ ,  $if_q$  and  $if_0$  are the stationary frame reference currents.  $E_{sd}$ ,  $E_{sq}$  and  $E_{s0}$  are the stationary frame reference voltages. Neglecting the zero sequence terms, the dynamics of the APF ac side variables in an SRF ( $dq$  frame) is derived. Since the  $d$  and  $q$  components are orthogonal. Hence  $V_{fd}$  and  $V_{fq}$  from Equation (8) are considered for SVPWM switching signals generation.

**I. IMPROVED SVPWM ALGORITHM FOR APF**

The voltage space vector synthesization is critical in the conventional SVPWM method. As it uses Clarke transformation to transform the reference voltages to  $d-q$  coordinates in order to generate reference vectors. Subsequently, the reference vectors are synthesized by some optimally selected basic vectors with specific time duration. In that method, the sectors of reference vectors are determined by their phase angles, and the time duration of basic vectors are calculated through the computation of phase angles and reference vectors. As these computations involve huge quantities of irrational numbers and trigonometric functions, the computation burden would be enormous. These operations may bring about major calculation errors which would corrupt the performance of shunt APF. To solve this problem, an effective time concept based SVPWM is used to generate the switching signals. It is possible to reconstruct the actual gating time without separation and recombination effort. The switching state diagram of the VSI is shown in Fig4. The six non-null states are represented by space vectors

mathematically represented as follows

(10)

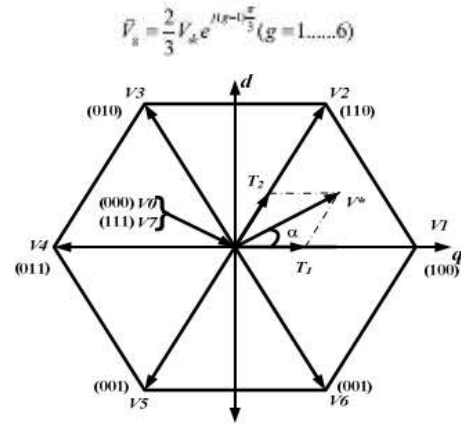

**Fig.4.VSI Switching States Vectors.**

The APF reference voltages  $V_{sa}^*$ ,  $V_{sb}^*$  and  $V_{sc}^*$  for each phase are found from the stationary reference voltages.

$$\begin{pmatrix} V_{sa}^* \\ V_{sb}^* \\ V_{sc}^* \end{pmatrix} = \begin{pmatrix} -\frac{1}{2} & -\frac{\sqrt{3}}{2} \\ -\frac{1}{2} & \frac{\sqrt{3}}{2} \\ 1 & 0 \end{pmatrix} \begin{pmatrix} V_{dq} \\ V_{d0} \end{pmatrix} \tag{11}$$

In order to obtain the actual switching time directly from the APF phase voltages, the stationary reference frame voltages are utilized and effective times are transformed to the phase voltages using equation (11).

$$\begin{aligned} &= \frac{T_1}{V_{dc}} \left[ \left( -\frac{1}{2} V_{sa} - \frac{\sqrt{3}}{2} V_{sb} \right) - \left( -\frac{1}{2} V_{sa} + \frac{\sqrt{3}}{2} V_{sb} \right) \right] \\ &= \frac{T_1}{V_{dc}} V_{sa}^* - \frac{T_2}{V_{dc}} V_{sb}^* = T_{1a} - T_{2a} \end{aligned} \tag{12}$$

From the equations (11) and (12), the effective times  $T1$ ,  $T2$  can be calculated by the time difference between the times  $T_{sa}$ ,  $T_{sb}$  and  $T_{sc}$  matching to the phase voltages. Furthermore, in the remaining sectors case, the effective times can be substituted with the phase voltage times in



the same method described above. This result, demonstrates that the effective time calculated in the conventional SVPWM is the difference between two applied times resultant to the phase voltage. Hence, despite of the sector location of the reference vector, the resultant times for each phase voltages are defined as following.

$$\begin{aligned}
 T_{ga} &= \frac{T_s}{V_{dc}} V_{a}^* \\
 T_{gb} &= \frac{T_s}{V_{dc}} V_{b}^* \\
 T_{gc} &= \frac{T_s}{V_{dc}} V_{c}^*
 \end{aligned}
 \tag{13}$$

The effective time  $T_{eff}$  will be defined as the time duration between  $T_{max}$  and  $T_{min}$ , and the effective voltage is supplied to the VSI during this time interval. Therefore, the actual switching times for each VSI arm can be obtained as follows.

$$\begin{aligned}
 T_{ga} &= T_{sa} + T_{offset} \\
 T_{gc} &= T_{sc} + T_{offset}
 \end{aligned}
 \tag{14}$$

To allocate the zero voltage symmetrically during one sampling period, the offset time  $T_{offset}$  is calculated as follows. The switching pulse pattern is shown in Fig5.

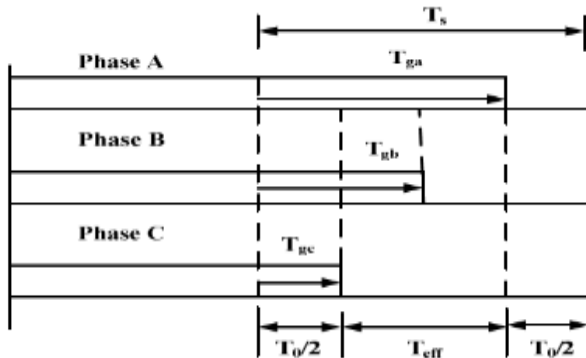

**Fig.5. Proposed shunt APF switching pattern.**

$$\begin{cases}
 T_{eff} = T_{max} - T_{min} \\
 T_0 = T_s - T_{eff}
 \end{cases}$$

$T_{min} + T_{offset} = T_0/2$  Therefore  $T_{offset} = T_0/2 - T_{min}$

(16)

By using the effective time concept, the actual switching times can be directly computed from the stationary reference frame voltages. Therefore, the computation effort of the proposed PWM method is greatly reduced. With this PWM method the Harmonic compensation signals are generated at PCC using VSI.

### I. INTRODUCTION TO FUZZY LOGIC CONTROLLER

A new language was developed to describe the fuzzy properties of reality, which are very difficult and sometime even impossible to be described using conventional methods. Fuzzy set theory has been widely used in the control area with some application to dc-to-dc converter system. Furthermore, design of fuzzy logic controller can provide desirable both small signal and large signal dynamic performance at same time, which is not possible with linear control technique. Thus, fuzzy logic controller has been potential ability to improve the robustness of dc-to-dc converters. The basic scheme of a fuzzy logic controller is shown in Fig 5 and consists of four principal components such as: a fuzzy fication interface, which converts input data into suitable linguistic values; a knowledge base, which consists of a data base with the necessary linguistic definitions and the control rule set; a decision-making logic which, simulating a human decision process, infer the fuzzy control action from the knowledge of the control rules and linguistic variable definitions; a de-fuzzification interface which yields non fuzzy control action from an inferred fuzzy control action [10].

(15)

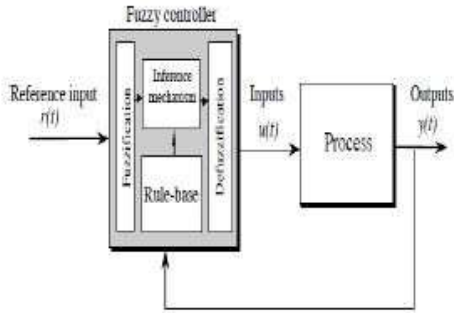

**Fig.6. General structure of the fuzzy logic controller on closed-loop system.**

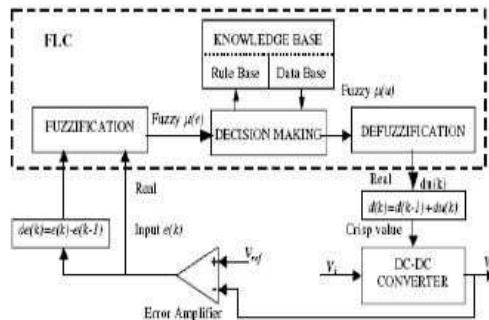

**Fig.7. Block diagram of the Fuzzy Logic Controller (FLC) for dc-dc converters.**

The fuzzy control systems are based on expert knowledge that converts the human linguistic concepts into an automatic control strategy without any complicated mathematical model [10]. Simulation is performed in buck converter to verify the proposed fuzzy logic controllers.

**A. Fuzzy Logic Membership Functions:**

The dc-dc converter is a nonlinear function of the duty cycle because of the small signal model and its control method was applied to the control of boost converters. Fuzzy controllers do not require an exact mathematical model. Instead, they are designed based on general knowledge of the plant. Fuzzy controllers are designed to adapt to varying operating points. Fuzzy Logic Controller is designed to control the output of boost dc-dc converter using Mamdani style fuzzy inference system. Two input variables, error (e) and change of error (de) are used in this fuzzy logic system. The single

output variable (u) is duty cycle of PWM output.

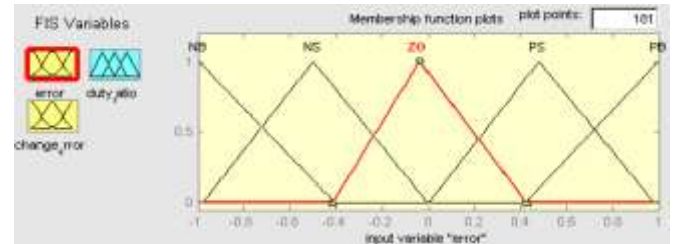

**Fig.8. The Membership Function plots of error.**

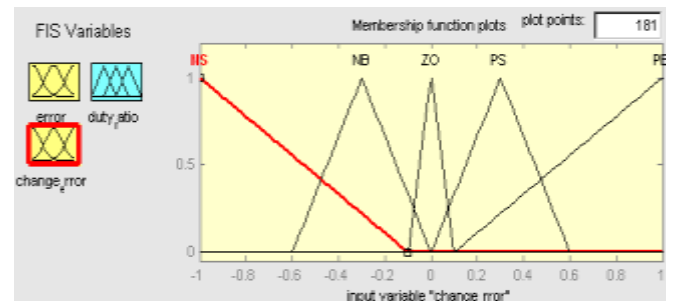

**Fig.9. The Membership Function plots of change error.**

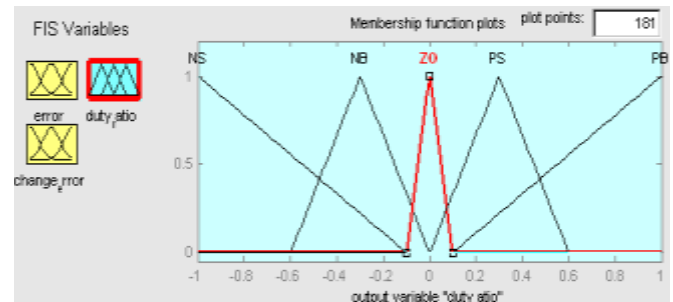

**Fig.10. The Membership Function plots of duty ratio.**

**B. Fuzzy Logic Rules**

The objective of this dissertation is to control the output voltage of the boost converter. The error and change of error of the output voltage will be the inputs of fuzzy logic controller. These 2 inputs are divided into five groups; NB: Negative Big, NS: Negative Small, ZO: Zero Area, PS: Positive small and PB: Positive Big and its parameter [10]. These fuzzy control rules for error and change of error can be referred in the table that is shown in

Table II as per below:

**Table II. Table rules for error and change of error**

(de) \ (e)	NB	NS	ZO	PS	PB
NB	NB	NB	NB	NS	ZO
NS	NB	NB	NS	ZO	PS
ZO	NB	NS	ZO	PS	PB
PS	NS	ZO	PS	PB	PB
PB	ZO	PS	PB	PB	PB

**V. SIMULATION RESULTS**

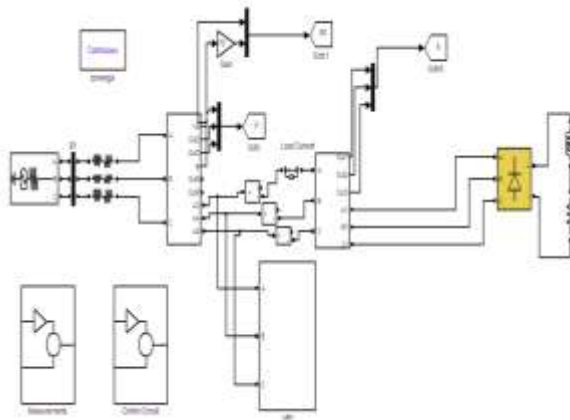

**Fig.11. Matlab/Simulink model of shunt active power filter for compensation of power systems harmonics.**

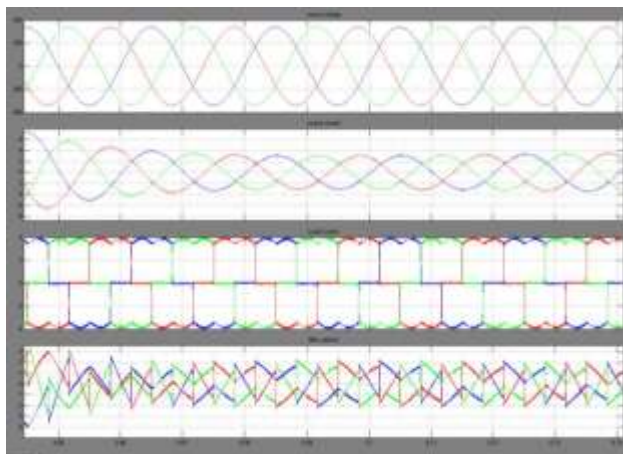

**Fig.12. Shows three phase bus voltages, currents, load current and compensating currents.**

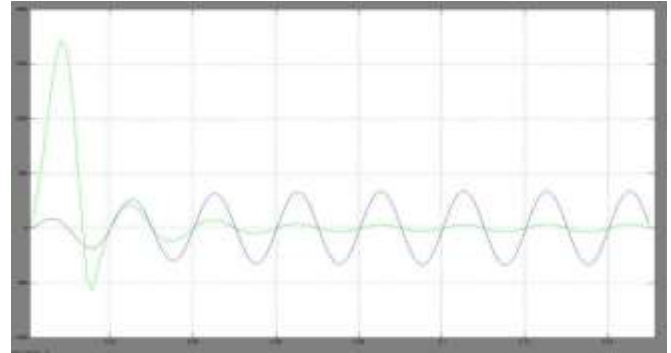

**Fig.13. Shows output waveform of power factor.**

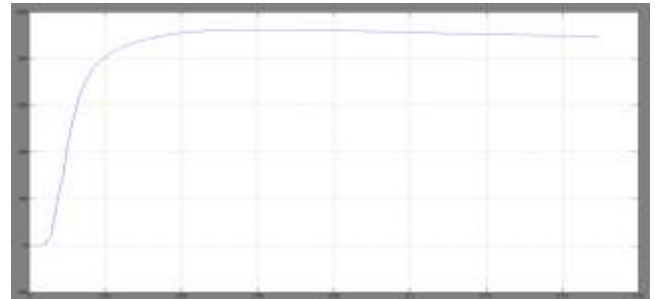

**Fig.14. Shows output waveform of DC-bus voltage.**

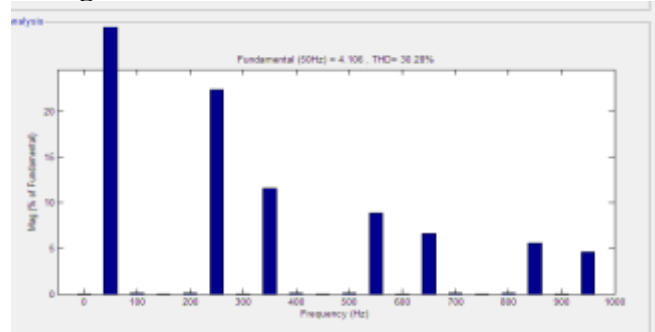

**Fig.15. FFT analysis of without shunt APF THD-30.28%.**

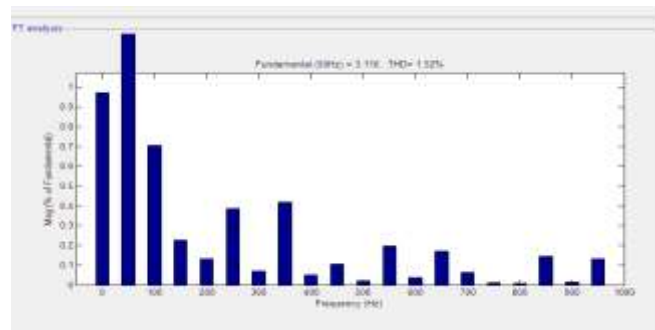

**Fig.16. FFT analysis of with shunt APF THD-1.52%**

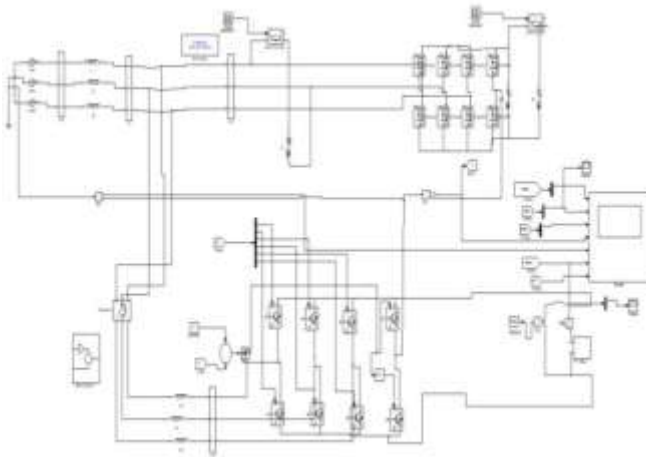

**Fig.17. Matlab/Simulink model of fuzzy based four leg shunt active power filter.**

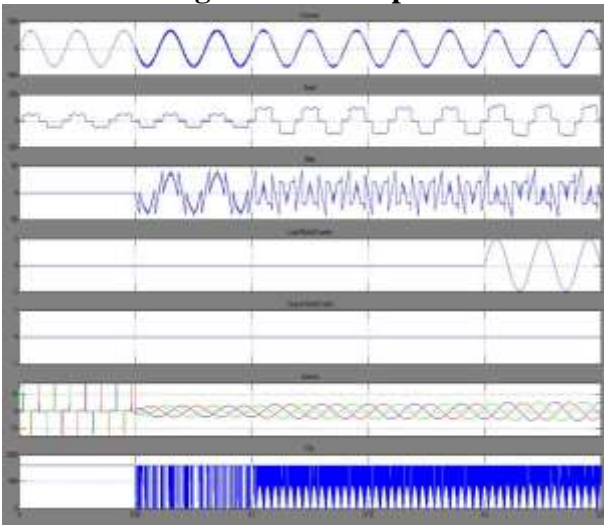

**Fig.18. Shows source voltage, load currents, neutral currents, source neutral currents, source currents and DC-bus voltage**

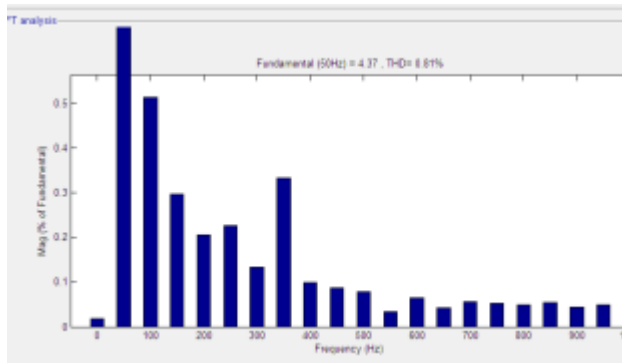

**Fig.19. FFT analysis of fuzzy based shunt APF THD- 0.81%**

**I. CONCLUSION**

This paper presents a three phase three wire shunt active power filter as a reliable and cost-effective solution to power quality problems. When the active filter is installed at a distorted and unbalanced distribution network, the harmonic are compensated by the active filter. Therefore, the source needs to supply only balanced, sinusoidal currents which are in-phase with balanced positive-sequence fundamental voltage. The proposed low-cost solution allows the use of a large number of low-power active filters in the same facility, close to each problematic load (or group of loads), avoiding the circulation of current harmonics, reactive currents and neutral currents through the facility power lines. This solution reduces the power lines losses and voltage drops

and avoids voltage distortions at the loads terminals. The proposed Shunt Active Power Filter (SAPF) can compensate for variable nonlinear load currents. PI or fuzzy controllers are used for compensation of load currents. Fuzzy is better than pi because fuzzy has lower harmonic distortion value.

**I. REFERENCES**

[1] Recommended Practice for Harmonic Control in Electric Power Systems, IEEE Std. 519-1992, 1992.  
 [2] F. Z. Peng, "Application issues of active power filters," IEEE Ind. Appl. Mag., vol. 4, no. 5, pp. 21--30, Sep./Oct. 1998.  
 [3] S. Rahmani, N. Mendalek, and K. Al-Haddad, "Experimental design of a nonlinear control technique for three-phase shunt active power filter," IEEE Trans. Ind. Electron., vol. 57, no. 10, pp. 3364–3375, Oct. 2010.  
 [4] H. Hu, W. Shi, Y. Lu, and Y. Xing, "Design considerations for DSP controlled 400 Hz shunt active power filter in an aircraft power system," IEEE Trans. Ind.



Electron., vol. 59, no. 9, pp. 3624–3634, Sep. 2012.

[5] Z. Chen, Y. Luo, and M. Chen, "Control and performance of a cascaded shunt active power filter for aircraft electric power system," *IEEE Trans. Ind. Electron.*, vol. 59, no. 9, pp. 3614--3623, Sep. 2012.

[6] D. Shen, and P. W. Lehn. "Fixed-frequency space-vector-modulation control for three-phase four-leg active power filters." *IEE Proceedings Electric Power Applications* 149, no. 4, pp.268-274, July, 2002.

[7] D.Chen, and S.Xie, "Review of the control strategies applied to active power filters" In *Electric Utility Deregulation, Restructuring and Power Technologies, (DRPT 2004). Proceedings of the 2004 IEEE International Conf on* vol. 2, pp. 666-670, April, 2004.

[8] W.Jianze, P.Fenghua, W.Qitao, J.Yanchao, & Y.Du, "A novel control method for shunt active power filters using svpwm" In *IEEE Industry Applications Conf, 2004. 39th IAS Annual Meeting.* vol.1, pp.129-134, Oct, 2004.

[9] M.P.Kazmierkowski, M.A.Dzieniakowski, and W.Sulkowski, "Novel space vector based current controllers for PWM-

inverters" *IEEE Trans. Power Electronics*, vol.6, no.1, pp.158- 166. Jan, 1991.

[10] M. A. Jabbar, Ashwin M. Khambadkone, and Zhang Yanfeng. "Spacevector modulation in a two-phase induction motor drive for constant power operation." *IEEE Trans. Ind. Electron.*, vol.51, no. 5, pp.1081- 1088, Oct, 2004.

[11] Mendalek, Nassar, and Kamal Al-Haddad. "Modeling and nonlinear control of shunt active power filter in the synchronous reference frame." in *Proc. 2000 IEEE Ninth Harmonics and Quality of Power International Conf (ICHQP)*, vol. 1, pp. 30-35.

[12] Massoud, A. M., S. J. Finney, and B. W. Williams. "Review of harmonic current extraction techniques for an active power filter." In *Proc. 2004 IEEE 11th Harmonics and Quality of Power International Conf (ICHQP)*, pp. 154-159.

[13] B. Bahrani, S. Kennelmann, and A. Rufer, "Multivariable-pi-based dq current control of voltage source converters with superior axis decoupling capability," *IEEE Trans. Ind. Electron.*, vol. 58, no. 7, pp. 3016 –3026, July 2011.