

A STUDY ON FRICTION STIR WELDING OF VARIOUS ALUMINIUM ALLOYS**CH ASHOK**

Asst.Prof

Machine Design

Dept Of Mech

GDMM CET, Nandigama

T.CH NAGARAJU

Asst.Prof

Machine Design

Dept Of Mech

GDMM CET ,Nandigama

ABSTRACT

Friction Stir Welding (FSW) is a unique welding method and new invention for the welding technology world. FSW will not change the microstructure of the metal diverse unlike the conventional welding. It also can reduce the cost if compared to the conventional welding cost. It involves the joining of metals without fusion or filler materials. The comprehensive body of knowledge that has built up with respect to the friction stir welding (FSW) of aluminum alloys since the technique was invented in 1991 is reviewed on this paper. The basic principles of FSW are described, including metal flow and thermal history, before discussing how process parameters affect the weld microstructure and the likelihood of defects. Finally, the range of mechanical properties that can be achieved is discussed. It is demonstrated that FSW of aluminum is becoming an increasingly mature technology with numerous commercial applications.

Keywords - Friction stir welding, metal flow, process parameters, mechanical properties.

I. INTRODUCTION

FSW process, a so-called welding-head pin rotating at speeds usually in excess of a few hundred rpm, travels down the length of contacting metal plates, creating a highly plastically deformed zone through the associated force and frictional heating. FSW of Aluminium to Aluminium has captured important attention from manufacturing industries, such as Shipbuilding, Automotive, Railway and Aircraft production. Variable Process Parameters have been employed to analyse the influence of Microstructural and Tensile Properties. Effect of welding speed

on microstructures, hardness distribution and tensile properties of the welded joints were investigated. By varying the process parameters, defect free and high efficiency welded joints were produced. A method of solid phase welding, which permits a wide range of parts and geometries to be welded are called Friction Stir Welding (FSW), was invented by W.Thomas and his colleagues at The Welding Institute (TWI), UK, in 1991. Friction stir welding has a wide application potential in ship building, aerospace, automobile and other manufacturing industries. The process proves predominance for welding non-heat treatable or powder metallurgy Aluminum alloys, to which the fusion welding cannot be applied. Thus fundamental studies on the weld mechanism, the relation between microstructure, mechanical properties and process parameters have recently been started. Friction stir welding is a relatively simple process as shown in Fig.1. In recent times, focus has been on developing fast, efficient processes that are environment friendly to join two dissimilar materials. The spotlight has been turned on Friction stir welding as a joining technology capable of providing welds that do not have defects normally associated with fusion welding processes. Friction stir welding (FSW) is a fairly recent technique that utilizes a non consumable rotating welding tool to generate frictional heat and plastic deformation at the welding location, thereby affecting the formation of

a joint while the material is in the solid state. Figure.1 shows the schematic drawing of friction stir welding representing all the relevant parameters of the process.

[1] A rotating tool is pressed against the surface of two abutting or overlapping plates. The side of the weld for which the rotating tool moves in the same direction as the traversing direction, is commonly known as the 'advancing side'; the other side, where tool rotation opposes the traversing direction, is known as the 'retreating side'

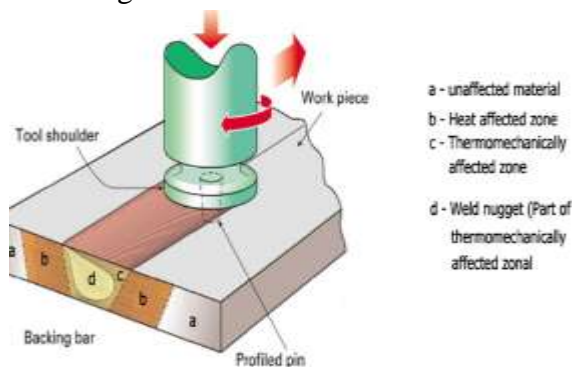

Figure.1: Schematic illustration of Friction Stir Welding

II. APPLICATIONS

Commercial applications have been reported across many industries, and some selected examples are shown below which illustrate the widening appeal of the process. This list is representative rather than exhaustive, and it should be emphasized that new applications are appearing all the time. It should be noted that FSW does not restrict the operating temperature range of aluminum alloys, with applications ranging from cryogenic temperatures (e.g. liquid oxygen and liquid hydrogen rocket fuel tanks) to mildly elevated temperatures (e.g. heat exchangers in heating systems). Most

FSWs used in production are butt welds, although lap welds and friction stir spot welds are also being applied with increasing frequency.

III. FLOW MECHANISMS AND TOOL DESIGN

The metal flow and heat generation in the softened material around the tool are fundamental to the friction stir process. Material deformation generates and redistributes heat, producing the temperature field in the weld. But since the material flow stress is temperature and strain rate sensitive, the distribution of heat is itself governed by the deformation and temperature fields. In fact their control lies at the core of almost all aspects of FSW, for example, the optimization of process speeds and machine loading, the avoidance of macroscopic defects, the evolution of the microstructure, and the resulting weld properties.

Early work on the mode of material flow around the tool used inserts of a different alloy, which had a different contrast to the normal material when viewed through a microscope, in an effort to determine where material was moved as the tool passed [2,3].

More recently, an alternative theory has been advanced that advocates considerable material movement in certain locations

[4]. This theory holds that some material does rotate around the pin, for at least one rotation, and it is this material movement that produces the "onion-ring" structure in the stir zone. The researchers used a combination of thin copper strip inserts and a "frozen pin" technique, where the tool is rapidly stopped in place. They

suggested that material motion occurs by two processes:

1. Material on the advancing front side of a weld enters into a zone that rotates and advances with the pin. This material was very highly deformed and sloughs off behind the pin to form arc-shaped features when viewed from above (i.e. down the tool axis).

It was noted that the copper entered the rotational zone around the pin, where it was broken up into fragments. These fragments were only found in the arc shaped features of material behind the tool.

2. The lighter material came from the retreating front side of the pin and was dragged around to the rear of the tool and filled in the gaps between the arcs of advancing side material. This material did not rotate around the pin and the lower level of deformation resulted in a larger grain size. [5]

To better visualize the flow of material around the welding tool, two new techniques were used.

First, small steel balls (0.38 mm diameter) were used as a tracer material embedded at different positions within butt joint welds of 6.4-mm-thick 6061-T6 and 7075-T6 plate. A weld was run along the length of the "seeded" butt joint and stopped at a point along the tracer pattern. By stopping the forward motion of the welding tool while it is still in the seeded material, the steel shot distribution around the welding tool is preserved in the end of the weld, revealing the path that the tracer material took in traveling around the welding tool. Each weld was subsequently radiographed to reveal the distribution of the tracer

material as it transitioned from its original position, around the welding tool and into the welded joint.

A number of techniques for embedding the steel tracer material were evaluated in preparation for the detailed experimental work in this study. However, the most effective method of embedding the tracer material involved machining a small groove, 0.7 mm high by 0.3 mm deep, along the butting edge of a plate of 6.4-mm aluminum and filling the groove with steel balls, as shown in Fig. 2. Prior to welding, the plates are forced together to imbed the 0.38-mm balls into the 0.3- mm groove. This technique results in a horizontal line of steel shot arranged at any desired position within the weld by making the groove at different depths and by orienting the butt joint at different lateral positions relative to the path of the welding tool. The initial tracer line locations are shown in Fig. 3 for the 6061 and in Fig. 4 for the 7075. Inspection of the weld by radiography then revealed the line of tracer material in advance of the welding tool, as the material was deforming around the tool, and after passage of the welding tool. The second technique used in this study involved ending friction stir welds by suddenly stopping the forward motion of the welding tool and simultaneously retracting the tool at a rate that caused the welding tool pin to unscrew itself from the weld, leaving the material within the threads of the pin intact and still attached to the keyhole. By sectioning the keyhole at the end of a weld that was made using this "stop action" technique, one can study the flow of material in the region immediately within the threads of the welding tool. This

technique requires the use of a numerically controlled (NC) milling machine. [6]

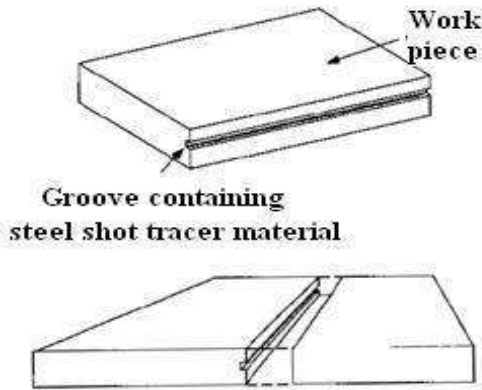

Fig. 2 — The tracer line technique employs a continuous line of 0.38 mm steel shot tracer material sprinkled into a small rectangular groove machined in the butting edge of a plate.

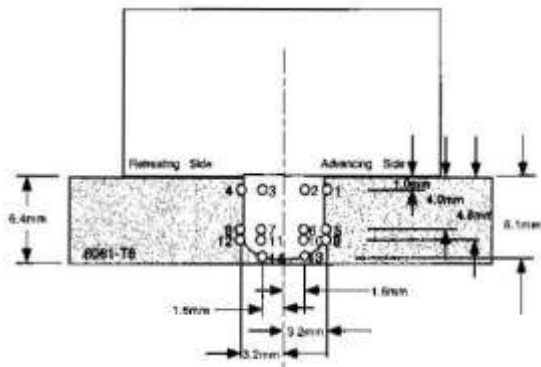

Fig. 3 — Tracer line positions for the 6.4-mm 6061-T6 plate. The groove containing the steel shot tracer material was oriented at various positions relative to the welding tool pin and at various depths in the work

piece plate, as shown in this schematic.

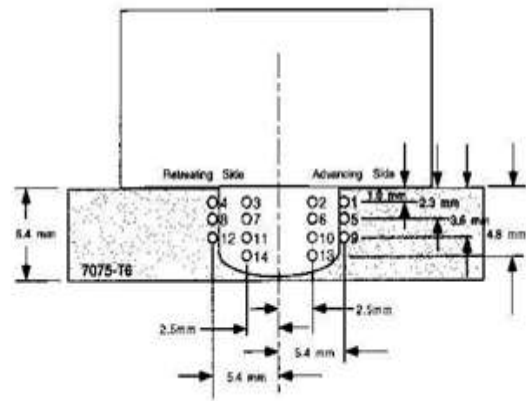

Fig. 4 — Tracer line positions for the 6.4-mm 7075-T6 plate. The groove containing the steel shot tracer material was oriented at various positions relative to the welding tool pin and at various depths in the work piece plate, as shown in this schematic.

IV. HEAT GENERATION AND PROCESS OPERATING REGIMES

Friction stir welding differs from competing processes such as arc and laser welding, since this use an external heat source of specified power, whereas in FSW the joining process itself generates the heat. The heat input is therefore a complex function of the process variables (traverse and rotation speeds, and down force), the alloy being welded, and the tool design. The effect of tool rotation and traverse speed on the heat input per second and per mm are shown in Fig.5a and b respectively [7]. Analytical estimates of heat input have assumed sliding Coulomb friction at the tool/work piece interface with a constant coefficient of friction, or sticking friction using an estimate of the limiting shear yield stress, or have inferred contact conditions and/or heat input from measurements of machine torque [8,9]. Thermocouple measurements coupled to heat flow analysis also provide a means to infer net power inputs. However, Peel et

al.[7] found no simple correlation between the temperature and the input power or heat. Although the heat input is commonly considered in fusion welding, it is a poor indicator of the temperature of the material surrounding an FSW tool, at least for the joining of thin plates of aluminum. It is likely that when the traverse speed is reduced, much of the additional heat is conducted into the backing plate, as evidenced by the observed correlation between the heat input and the backing plate temperature [7] as well as through the tool. The down force in FSW provides intimate thermal contact between work piece and backing plate, but this contact evolves with position during the welding process, requiring complex calibration [9]. The growing recognition of the importance and complexity of heat input has lead to the routine instrumentation of welding equipment, with spindle rotation speed and torque measurements now providing detailed power data.

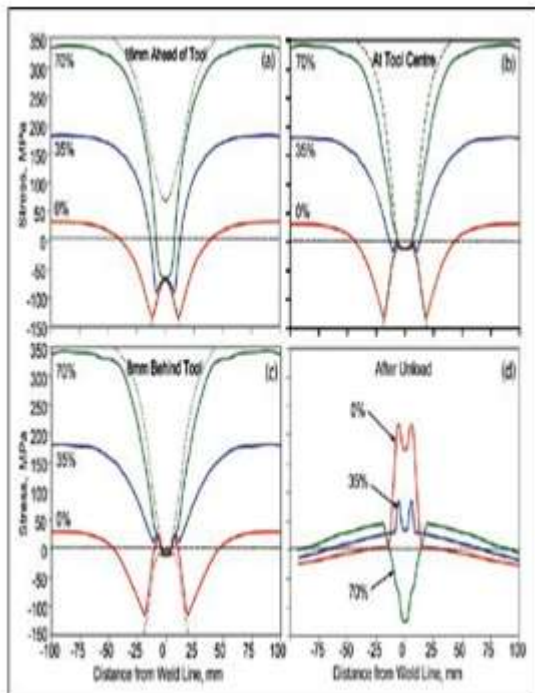

Fig.5. Rate of heat input a per millimeter of weld line and b per second for like to like and AA5083/AA6082 welds [7]

Heat is produced primarily by viscous dissipation in the work piece material close to the tool, driven by high shear stresses at the tool/work piece interface. The temperature and normal contact stresses vary widely over the tool, so it is unlikely that a single contact condition will be valid. Material at the interface may stick or it may slip, or there may be a combination of the two. As discussed above, local melting may occur as peak temperatures reach the solidus temperature. There may be then be oscillating stick slip behavior, as local melting rapidly reduces the shear stress, leading to a steep drop in local heat input and temperature, and self-stabilizing behavior. Process modeling using CFD has been used to explore the sensitivities of the heat generation, tool forces and size of deformation zone as a function of tool design and process conditions [9].

Recently the heat input has been calculated directly from the hot deformation constitutive response of the alloy, using a fully coupled deform

V. PROCESS PARAMETERS

In the FSW process, parameter selection and tool geometry are among the key factors that determine the quality of the fabricated joint. The value of the different parameters such as welding speed, rotational speed, tilt angle and pin geometry could lower the force exerted from the TMAZ section to the tool which improves the quality of the weld and less thermal energy is needed for the process prompting both sheets to reach the plastic state.

The plastic flow is responsible for obtaining the weld with high tensile strength and fewer defects and therefore the tool geometry plays a role in achieving a quality weld. Taguchi's technique is a powerful tool in quality optimization. Taguchi's technique makes use of a special design of orthogonal array (OA) to examine the quality characteristics through a minimal number of experiments [11].

Functional parameters involved during the Friction Stir Welding [FSW] process is considered as numerical data and applied it over a Hyper Geometric Function and changes in Gamma values are studied. The aim of welding needs to be defect free which requires uniform distribution of weld bead. This uniform distribution is dependent on functional parameters viz., welding rotational speed, weld transverse speed and axial load. [12]

An FSW joint usually consists of four different regions. They are (a) Unaffected base metal (b) Heat affected zone (HAZ)

(c) Thermo mechanically affected zone (TMAZ) and (d) stir (SZ) zone. The formation of above regions is affected by the material flow behavior under the action of rotation non-consumable tool however; the material flow behavior is predominantly influenced by the FSW tool profiles and FSW process parameters. Fig. 6 represents the transverse section various zones of FSW process.

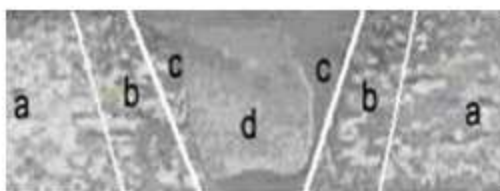

Fig.6 Different regions of FSW joint: (a)

unaffected base metal; (b) heat affected zone (HAZ); (c) thermo-mechanically affected zone (TMAZ); (d) Stir (SZ) zone.

The percentage of elongation and the tensile strength values are very less for the entire tensile tested specimen and they are cracked at the welded area (stirred zone) where least strength is identified comparing to two base metals for the tested range of rotational and welding speed parameters. Since the temperature range is 90 to 1500C for which the base alloys are not soften with stirring. If we go for lower welding speeds in the range 90-120mm/min and the rotational speed between 800-900rpm, we can get the high impact and bending strength for both the pin profiles combinations. The Tunnel hole defect is identified for all the tested specimens in the AA7075 side (advancing side) and it is minimum for the rotational speed 900rpm and welding speed 150mm/min whereas is maximum to 800rpm and for both 200 & 250mm/min.[13]

Figure 7 shows that the cross-section image of friction stir welded AA6061-T6 and Ti-6Al-4V alloy (a) and the optical microscopy (OM) images of the cross-section (b-g). The stir zone occurs mainly on the aluminum side of joint. Because tool was shifted towards AA6061-T6, SZ was formed mostly on the AA6061-T6 of the weld zone. Ti-6Al-4V alloy fragments were observed in SZ (Fig. 7(a)). SZ was composed of finely recrystallized aluminum alloy grains and titanium alloy fragments pushed away from the titanium base metal due to the stirring effect of the probe.

Therefore SZ has a composite structure of aluminum alloy reinforced by titanium

particles. Middle area of the weld interface evaluated by OM is shown in Fig. 7(c). Titanium alloy fragments were also observed in SZ. However, they were not found in the probe tip area of the weld interface (Fig. 7(d)). This is why the probe did not stir the titanium alloy in direction. Crystal grains of the aluminum alloy in SZ (Fig. 7 (e)) became significantly fine compared with the initial grain size of aluminum alloy base metal Fig. 7(f). Figure 7(g) shows Titanium alloy base metal around the weld interface. [14]

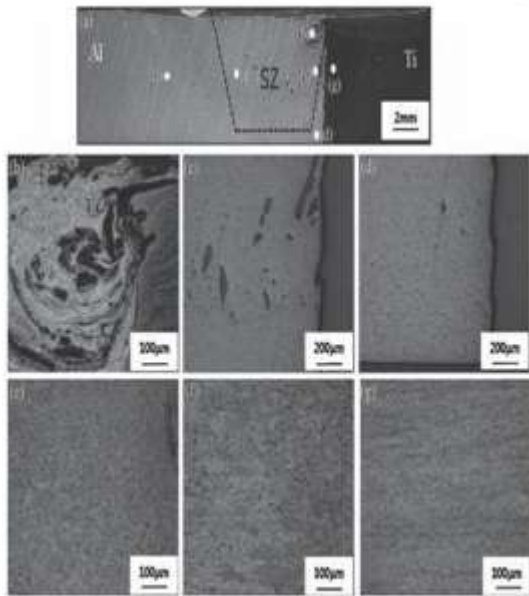

Fig. 7 (a) Macro image of weld zone, (b) probe root area of interface, (c) middle area of interface, (d) probe tip area of interface, (e) SZ of AA6061-T6, (f) BM of AA6061-T6, (g) BM of Ti-6Al-4V.

V. CONCLUSION

The present review has demonstrated the extensive research effort that continues to progress the understanding of FSW of aluminum alloys and its influence on their microstructure and properties. It identifies a number of areas that are worthwhile for further study. From an engineering perspective, there is a need to investigate

the occurrence and significance of flaws in friction stir welds. In particular, the influence of tool design on flaw occurrence and the development of nondestructive testing techniques to identify flaws in both lap and butt welds would be beneficial. Metal flow modeling may have a role to play here, though capturing this aspect of the thermo mechanical behavior remains a significant challenge.

REFERENCES

- [1] Ahmed Khalid Hussain, *Evaluation of Parameters of Friction Stir Welding*, 20september 2012, 2012h.
- [2] S.T. Amancio-Filho, S. Sheikhi, J.F. dos Santos, C. Bolfarini, *Preliminary study on the microstructure and mechanical properties of dissimilar friction stir welds in aircraft aluminium alloys 2024-T351 and 6056-T4*, *Journal of Materials Processing Technology*206 (2008) 132-142.
- [3] J.M. Timothy, "Friction Stir Welding of Commercially available Superplastic Aluminium", 2008, PhD thesis, Department of Engineering and Design Brunel Copper", *Scripta Materiaia*, Vol.57, July 2007.
- [4] M. Sivashanmugam, S. Ravikumar, T. Kumar, V. SeshagiriRao, D. Muruganandam, "A Review on Friction Stir Welding for Aluminium Alloys", 978-1-4244-9082- 0/10/\$26.00 ©2010 IEEE, pp. 216 – 221
- [5] Mandeep Singh Sidhu, Sukhpal Singh Chatha "Friction Stir Welding – Process and its Variables: A Review" *IJETAE Volume 2, issue 12, 2012*.
- [6] Threadgill., *Terminology in friction stir welding, Science and Technology of Welding and Joining, Vol 12 , No 4, 2007, 357- 360*.
- [7] ujicic, T He1, G Arakere, H V Yalavarthy, C-F Yen, and B A Cheeseman, *Fully coupled thermomechanical finite element analysis of material evolution during friction-stir welding of AA5083*, ASM International,. *Materials Park, Ohio, 2003, pp. 203–211*.
- [8]nolds, AP, . "Visualisation of material flow in autogenous friction stir welds". *Science and technology of welding and joining, Vol. 5 (2),2000, 120–124*.



[9]. Surendrababu, Dr. A. Gopala krishna, Dr. Ch. Srinivasa Rao, "Material Flow Behaviour in Friction Stir Welding Process-A Critical Review on Process Parameters and Modeling Methodologies", *International Journal of Emerging Technology and Advanced Engineering* , Volume 3, Issue 6, June 2013,219-225.

[10] COLLIGAN, *Material Flow Behavior during Friction Stir Welding of Aluminum*, *Welding research supplement*, July 1999. pp. 229s – 237s.

[11] J. Peel, A. Steuwer, P. J. Withers, T. Dickerson, Q. Shi and H. Shercliff: *Metall. Mater. Trans. A*, 2006,37A, 2183-2193.

[12] R. Shercliff and P. A. Colegrove: in 'Mathematical modelling of weld phenomena 6', (ed. H. Cerjak), *The Institute of Metals* , 2002, 927-974.

[13] R. Shercliff and P. A. Colegrove: in 'Friction stir welding and processing', (ed. R. S. Mishra et al.), *ASM International*, 2007,187-217; *Materials Park, OH*,.

[14] A. Colegrove and H. R. Shercliff, *CFD modelling of friction stir welding of thick plate 7449 aluminium alloy*, *Sci. Technol. Weld. Join.*,Vol.11, issue 4, 2006, 429-441.

[15] Muruganandam, D.Raguraman, Sushil Lal Das, "Analysis Of Mechanical Strength Of Dissimilar Aluminium Alloys AA7075

[17] Seidel, TU; Reynolds, AP, "Visualization of the Material Flow in AA2195 Friction-Stir Welds Using a Marker Insert Technique". *Metallurgical and Material Transactions* 32A,Vol.11, 2001, 2879–2884.