

NEW METHOD TO ELIMINATE COMMUTATION TORQUE RIPPLE OF BRUSHLESS DC MOTOR WITH A FRONT END IDO DC-DC CONVERTER

K.HARI KRISHNA

M.Tech (EEE), Department of Electronics and Electrical Engineering, Helapuri Institute of Technology and Science, Eluru, A.P.

Mr. K.MAHESH

Assistant Professor, Department of Electronics and Electrical Engineering, Helapuri Institute of Technology and Science, Eluru, A.P.

Abstract

This paper proposes a front end integrated dual output (IDO) dc-dc converter for commutation torque ripple reduction in a permanent magnet brushless DC (BLDC) motor drive. The current ripple owed to the inductance and resistance of the motor during commutation instant results in torque ripple. In this work the dc link voltage of the converter is varied at commutation instants to minimize current ripple and hence torque ripple. The wider output range and faster response of the IDO converter make it a suitable choice as a front end converter for minimizing torque ripple. Simulation results validate the proposed converter for the BLDC motor drive. Experimental analysis of a conventional drive is performed to verify the simulation results.

Key words: Commutation torque ripple, brushless DC motor, integrated dual output dc-dc converter

1. Introduction

Permanent magnet BLDC motors are gaining recognition in the electric drive market due to their high efficiency, low maintenance, high power density, and low electromagnetic interference problem [1-5]. Commutation torque ripple is a serious drawback of the BLDC motor that occurs due to current distortions during phase transitions. Torque ripple in a BLDC motor drive gives rise to mechanical vibrations and acoustic noise. Researchers have proposed modified PWM control, DC bus voltage control, current control, torque control, and phase conduction control based torque ripple minimization strategies for BLDC motor drives.

In [6], the torque and torque ripple in a BLDC motor drive is analyzed in detail with the commutation effect taken into consideration. The modification in

electronically controlled commutation based on Fourier coefficients for minimizing torque ripple in BLDC motors is presented in [7]. A methodology based on finite-state model predictive control for BLDC motors to reduce commutation torque ripple is proposed in [8]. A vector analysis has been incorporated in a BLDC motor drive and a method of synthesizing the current supply for torque ripple-free operation has been proposed in [9]. Another approach for minimizing commutation torque ripple by implementing a Z-source inverter fed BLDC motor has been explained in [10]. In [11], the technique for torque ripple compensation in a low power BLDC motor is proposed without a DC link capacitor.

In [12,13], the influence of different PWM modes in reducing commutation torque ripple is discussed. The variation in DC input voltage for minimizing torque ripple in a BLDC motor is proposed by Ki-Yong et al.

[14]. This method reduces the current ripples and hence torque ripple by varying the input voltage. The current control method using a single DC current sensor is proposed by Joong-Ho [15]. The incoming and outgoing of current response are equalized by controlling the duty ratio, thus reducing commutation torque ripple. A new torque control method for minimizing torque ripple is proposed in [16], which generates ideal current pulses with respect to back emf waveforms. Torque ripple minimization by altering the switching

angles per half cycle of the inverter is discussed in [17]. The effectiveness of DC voltage control has prompted researchers to analyze several front end converter topologies for torque ripple minimization. In [18,19], the input voltage adjustment for reducing torque ripple is performed by front-end buck and super lift Luo converter. Here the dc link voltage to the inverter is adjusted during conduction and commutation time instants in order to reduce torque ripple. The new circuit topology called a single-ended primary inductor converter (SEPIC) [20] and a modified SEPIC (MSEPIC) converter [21] is employed in front of the inverter to produce the desired dc link voltage to suppress commutation torque ripple. Analysis of the above front-end converter topologies indicates that the response of the converter during commutation instant is vital to minimize torque ripple. In this paper, a front-end circuit topology is proposed with the objective of minimizing commutation torque ripple in a BLDC motor drive. The proposed circuit is composed of an integrated dual output (IDO) converter and a switch selection circuit, which is employed in front of the inverter for the desired DC link voltage selection. The performance of the converter is compared with that of a MSEPIC converter for highlighting the merits of the proposed converter for torque ripple minimization.

2. Modeling and commutation torque ripple analysis of a BLDC motor

This deviation of current profile as depicted in Figure 2 is responsible for torque ripple in the BLDC motor drive. Current ripple in the BLDC motor is calculated by the difference in reference and actual current at steady state condition. Torque ripple (TR) is defined as the percentage of difference between the maximum torque (T_{max}) and the

minimum torque (T_{min}) to the average torque (T_{avg}) for a particular time interval.

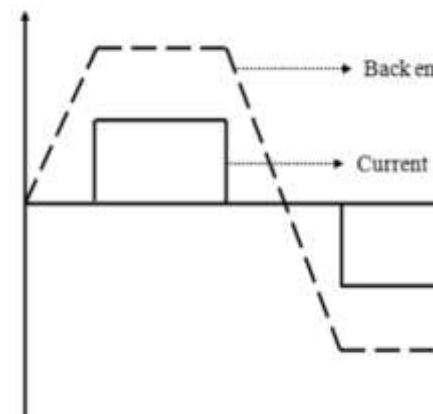

Figure 1. Ideal current and back emf waveform of BLDC motor drive.

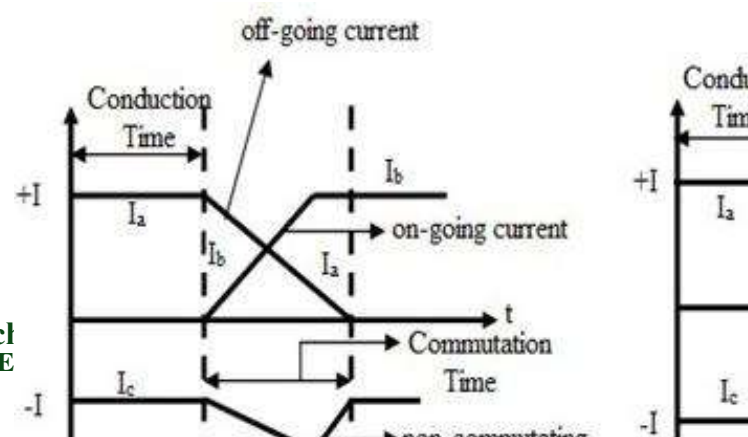

Figure 2. Commutation torque and current of BLDC motor during practical case.

To minimize the current deviations and hence torque ripple a front-end integrated dual output (IDO) dc-dc converter is proposed.

3. Integrated dual output dc-dc converter

The circuit topology of the IDO dc-dc converter is shown in Figure 3 and the design parameters are tabulated in Table 1. Here, the two different voltage levels are generated from a single input power source [24]. Here V_{dc} is the input source voltage and V_{01} and V_{02} are the two different levels of output voltage.

Figure 3. IDO dc-dc converter.

Table 1. Design specifications for IDO converter.

Parameter
Input voltage (V_{dc})
Step up output voltage (V_{01})
Step down output voltage (V_{02})
Switching frequency
Inductor (L_1)
Inductor (L_2)
Capacitor (C_1)
Capacitor (C_2)

The IDO converter has two switches Q_1 and Q_2 , resulting in three operating states as shown in Figure 4, which are discussed in the following sections.

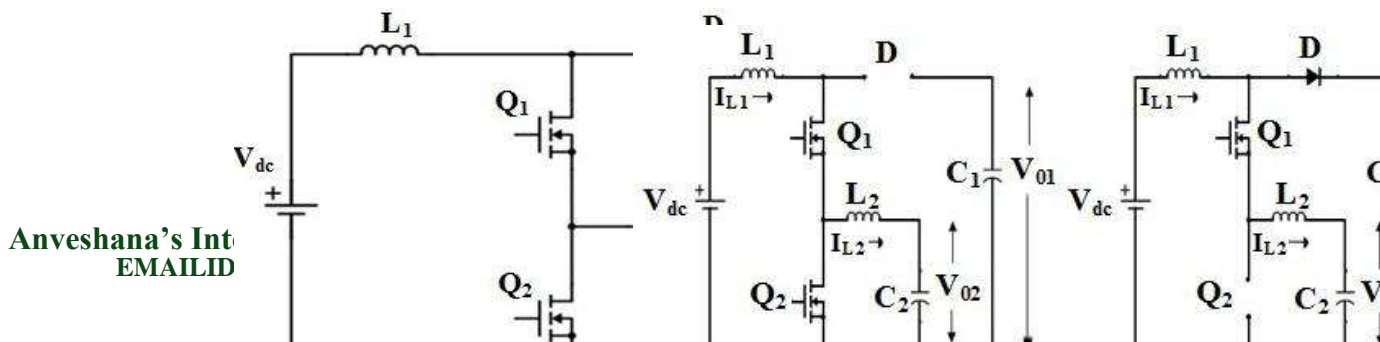



Figure 4. Operating modes of IDO dc-dc converter.



Interval I: In this interval both switches Q_1 and Q_2 are in ON state. Here the diode D_1 is reverse biased and the current I_{L1} passes through the inductor L_1 , whereas the inductor current I_{L2} freewheels through the switch Q_2 . The duty ratio at this Interval I is defined as D_1 .

Interval II: During this interval, switch Q_1 is ON and Q_2 is OFF and the inductor current I_{L1} flows through the diode D_1 and inductor L_2 . The diode current is equal to the difference between the inductor currents I_{L1} and I_{L2} . The duty ratio for this interval is defined as D_2 .

Interval III: During this interval, the switch Q_1 is OFF and Q_2 is ON. Here the inductor current I_{L2} freewheels through the switch Q_2 . Here the two inductors L_1 and L_2 give out the energy to their respective outputs. The two DC outputs of the IDO converter can be controlled using the corresponding duty cycles D_1 and D_2 . The boost mode operates when the switches Q_1 and Q_2 are turned ON simultaneously whereas the buck mode operates when the switch Q_1 is ON and Q_2 is OFF.

4. IDO dc-dc converter fed BLDC motor drive

The block diagram of the BLDC motor drive with the proposed front-end topology is presented in Figure 5. The major challenge in designing a controller for minimizing torque ripple using a front-end converter is to generate the required voltage at conduction and commutation time instants. In the proposed configuration this is achieved with a switch selection circuit that feeds the inverter with the correct voltage level during conduction and commutation time instants by varying the duty cycle of the IDO converter.

Figure 5. Block diagram of BLDC motor drive with proposed control strategy.

Throughout the conduction interval the voltage level V_{01} is applied to the inverter circuit in accordance with the speed and load command. During the commutation instant proposed circuit topology regulates the dc link voltage close to $4E_m$ [25] such that the rising and falling speeds of current are equal and hence the torque ripple is reduced. The duty cycle and the regulated dc voltage required under commutation time instants are calculated as follows.

5. Results and discussion

To analyze the performance of the BLDC motor drive with an IDO converter the simulation is done in MATLAB/Simulink environment. The parameters of the surface mounted BLDC motor used in this work are tabulated in Table 2.

Table 2. BLDC motor parameters.

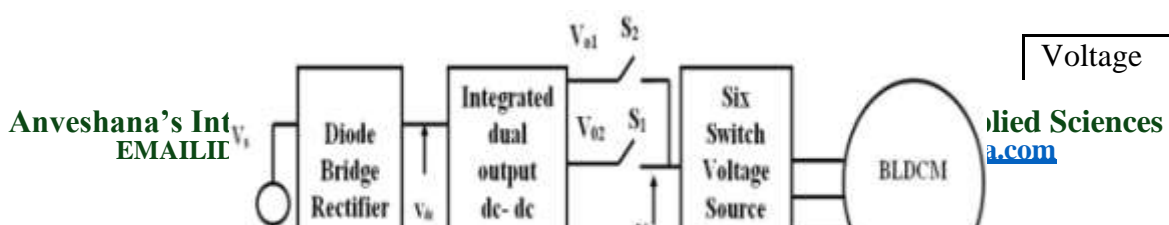

Voltage	31
---------	----



Rated current	4.52 A
Rated speed	4600 rpm
Rated power	1 hp
Stator phase resistance	3.07 Ω
Stator phase inductance	6.57 mH
Inertia	1.8e ⁻⁴ kg-m ²

Table 3. Torque ripple in conventional BLDC motor drive.

Speed (rpm)	% Torque ripple
100	14.69
300	29.67
1000	44.87

The conventional BLDC drive schematic without dc link voltage control is shown in Figure 7 and the torque ripple for the conventional method is indicated in Table 3 for different speeds. The robustness of the controller with the IDO converter fed BLDC motor is illustrated through the current, torque, and speed response with load and speed variation as shown in Figures 8 and 9, respectively.

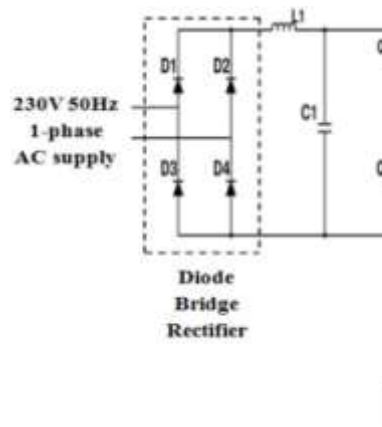

Figure 7. Schematic block diagram of the conventional BLDC motor drive.

To highlight the effectiveness of the proposed front-end IDO based DC-DC converter topology, simulation of the BLDC drive as shown in Figure 5 is performed to evaluate torque ripple under various loading conditions. The phase currents of the BLDC motor drive with and without the IDO converter at 1000 rpm speed and 0.5 Nm load with same operating conditions are compared in Figure 10. From the waveforms it is observed that the spikes during commutation time instant are smooth and the current is much closer to the ideal current waveform in the proposed topology. Figure 11 shows the electromagnetic torque response with and without the proposed topology. From the waveforms it is observed that the torque pulsations at commutation time instants are reduced in the proposed topology. The variation in DC link voltage at commutation instant of the IDO converter for different speeds is shown in Figure 12.

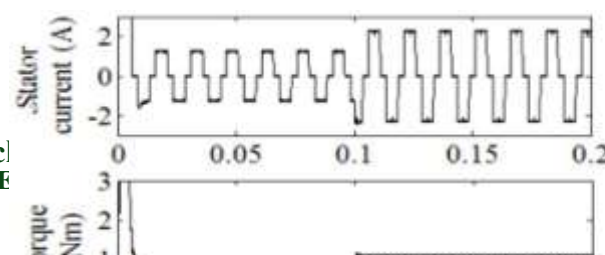



Figure 8. Simulated current, torque, and speed response for the proposed IDO converter based BLDC drive system with load variation.

Figure 9. Simulated current, torque, and speed response for the proposed IDO converter based BLDC drive system with speed variation.

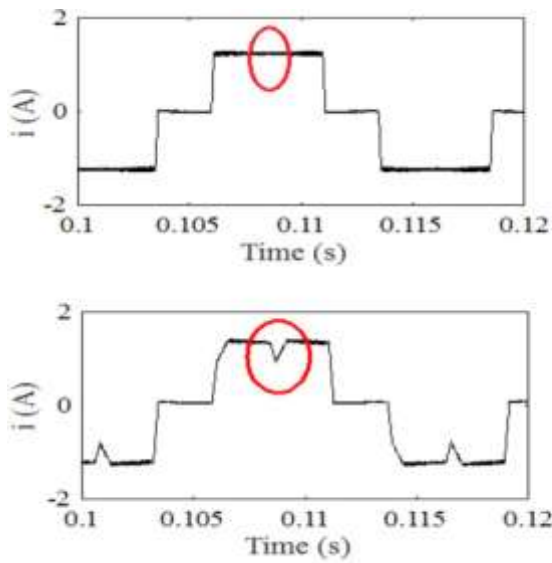

Figure 10. Phase currents at 1000 rpm. (a) With dc link voltage control by an IDO converter. (b) Without dc link voltage control.

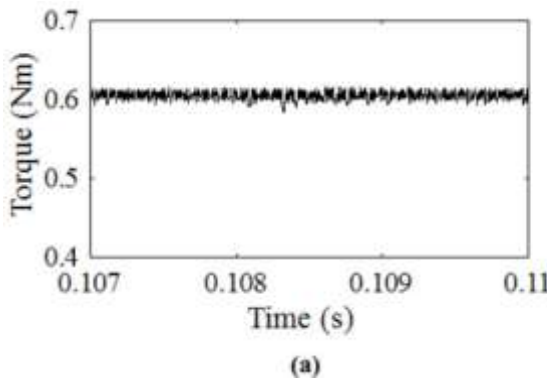

Figure 11. Electromagnetic at 1000 rpm. (a) With dc link voltage control by an IDO

converter. (b) Without dc link voltage control.

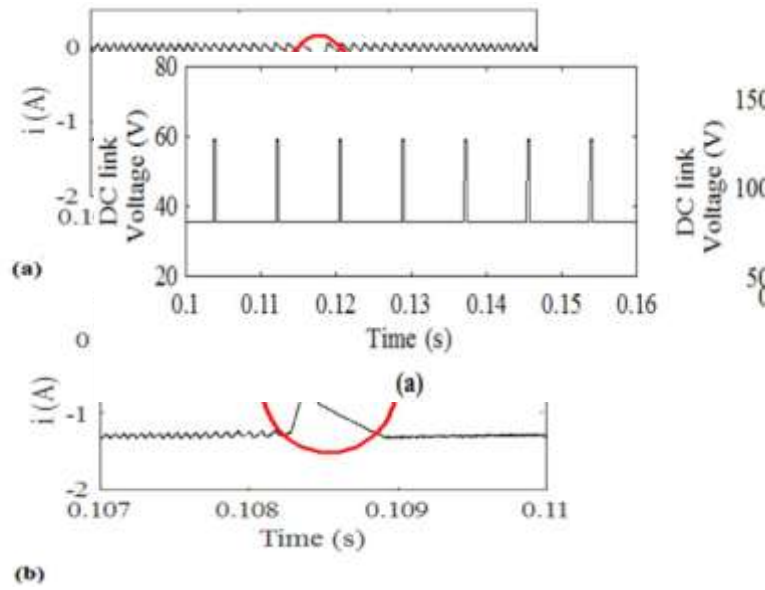

Figure 12. Dc link voltage at (a) 300 rpm, (b) 1000 rpm.

6. Conclusion

In this paper, integrated dual output-based front end dc-dc converter topology for torque ripple minimization is proposed. The voltage levels of the proposed topology are varied during conduction and commutation instants according to the speed and load variations. From the results it is observed that a considerable reduction in torque ripple is achieved in comparison with the conventional BLDC drive and MSEPIC converter fed drive. Hardware validation of the conventional drive is done to substantiate the simulation results. The fast voltage adjustment feature of the topology with minimum components augurs well for its suitability in variable speed applications.



References

- [1] Rodriguez F, Emadi A. A novel digital control technique for brushless DC motor drives. *IEEE T Ind Electron* 2007;
- [2] Sathyan A, Milivojevic N, Lee YJ, Krishnamurthy M, Emadi A. An FPGA-based novel digital PWM control scheme for BLDC motor drives. *IEEE T Ind Electron* 2009; 56: 3040-3049.
- [3] Milivojevic N, Krishnamurthy M, Gurkaynak Y, Sathyan A, Lee YJ, Emadi A. Stability analysis of FPGA-based control of brushless DC motors and generators using digital PWM technique. *IEEE T Ind Electron* 2012; 59: 343-351.
- [4] Aydogdu O, Akkaya R. An effective real coded GA based fuzzy controller for speed control of a BLDC motor without speed sensor. *Turk J Elec Eng & Comp Sci* 2011; 19: 413-430.
- [5] Yadav P, Poova R, Najamudeen K. High dynamic performance of a BLDC motor with a front end converter using an FPGA based controller for electric vehicle application. *Turk J Elec Eng & Comp Sci* 2016; 24: 1636-1651.
- [6] Zerollg H, Boukais B, Sahraoui H. Analysis of torque ripple in a BDCM. *IEEE T Magn* 2002; 38: 1293-1296.
- [7] Aghili F. Ripple suppression of BLDC motors with nite driver/ampli er bandwidth at high velocity. *IEEE T Contr Syst T* 2011; 19: 391-397.