

POWER QUALITY IMPROVEMENT USING D - STATCOM IN 3 - PHASE 4 - WIRE SYSTEM

A. Sagar Kumar

M. Tech

Department of EEE

Moghal College of Engineering & Technology

ABSTRACT *This undertaking proposes another calculation to create reference voltage for a conveyance static compensator (DSTATCOM) working in voltage-control mode. The proposed plan shows a few favorable circumstances contrasted with conventional voltage-controlled DSTATCOM where the reference voltage is subjectively taken as 1.0 p.u. The proposed plan guarantees that almost solidarity power element (UPF) is accomplished at the heap terminal amid ostensible operation, which is unrealistic in the customary strategy. Likewise, the compensator infuses lower streams and, hence, decreases misfortunes in the feeder and voltage-source inverter. Further, a sparing in the rating of DSTATCOM is accomplished which builds its ability to moderate voltage droop. The Dstatcom model is composed by Reference voltage era alongside Instantaneous symmetrical segment hypothesis (P-Q Theory). With these components, this plan permits DSTATCOM to handle power-quality issues by giving force element adjustment, symphonious end, load adjusting, and voltage regulation taking into account the heap necessity. Reenactment results are displayed to show the viability of the proposed calculation.*

1.0 INTRODUCTION

Endeavor proposes another count to make reference voltage for a transport static compensator (DSTATCOM) working in voltage-control mode. The proposed plan demonstrates a couple of ideal circumstances appeared differently in relation to traditional voltage-controlled DSTATCOM where the reference voltage is subjectively taken as 1.0 p.u. The proposed plan ensures that just about solidarity power component (UPF) is accomplished at the heap terminal in the midst of apparent operation, which is implausible in the standard procedure. In like manner, the compensator mixes lower

streams and, thus, diminishes mishaps in the feeder and voltage-source inverter. Further, a sparing in the rating of DSTATCOM is accomplished which assembles its capacity to direct voltage droop. The Dstatcom model is composed by Reference voltage period close by Instantaneous symmetrical fragment hypothesis (P-Q Theory). With these components, this plan permits DSTATCOM to handle power-quality issues by giving power component change, symphonious end, load modifying, and voltage regulation considering the heap need. Reenactment results are displayed to demonstrate the suitability of the proposed computation.

POWER QUALITY

"To supply electric vitality to the purchaser terminals with slightest measure of unsettling influence is called power quality."

HISTORY

In the beginning of power transmission in the late nineteenth century problems like voltage deviation amid burden changes and power exchange constraint were seen because of responsive power unbalances. The greater part of the AC burdens are devouring receptive power because of presence of reactance. Substantial consumption of receptive power causes poor voltage quality. Today these Problems have much higher impact on solid and secure power supply in the realm of Globalization and Privatization of electrical frameworks and vitality exchange. The development in quick and

solid semiconductor gadgets (GTO and IGBT) permitted new power electronic Configurations to be acquainted with the undertakings of power Transmission and load stream control.

The FACTS gadgets offer a quick and solid control over the transmission parameters, i.e. Voltage, line impedance, and phase point between the sending end voltage and accepting end voltage. Then again the custom power is for low voltage conveyance, and improving the poor quality and unwavering quality of supply influencing touchy burdens. Custom power gadgets are fundamentally the same to the FACTS. Most generally known custom power gadgets are DSTATCOM, UPQC, DVR among them DSTATCOM is exceptionally understood and can provide financially savvy answer for the compensation of responsive power and unbalance stacking in circulation framework.

2.0 STRUCTURE OF DSATCOM AND OPERATION

Power quality and dependability cost the business extensive sums because of essentially lists and fleeting interferences. Mutilated and undesirable voltage wave shapes, as well. Also, the principle sympathy toward the purchasers of power was the unwavering quality of supply. Here we characterize the unwavering quality as the progression of supply. the issue of dispersion lines is separated into two noteworthy classifications. In the first place gathering is force quality, second is force unwavering quality. To begin with gathering comprises of consonant contortions, driving forces and swells. Second gathering comprises of voltage droops and blackouts. Voltage hangs is a great deal more genuine and can bring about a lot of harm. On the off chance that surpasses a couple cycle, engines, robots, servo drives and machine apparatuses can't keep up control of procedure.

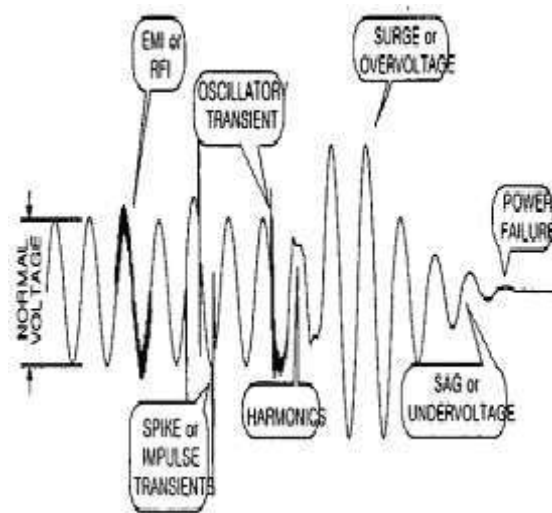

power quality and reliability

Both the unwavering quality and nature of supply are just as critical. For instance, a customer that is associated with the same transport that supplies a substantial engine burden might need to confront an extreme dunk in his supply voltage each time the engine burden is exchanged on. In some great cases even we need to shoulder the power outages which is not adequate to the buyers. There are additionally delicate loads, for example, healing facilities (life bolster, operation theater, and patient database framework), preparing plants, aviation authority, money related foundations and various other information handling and benefit suppliers that require perfect and continuous influence. In handling plants, a bunch of item can be demolished by voltage plunge of brief span. Such clients are exceptionally careful about such plunges following every plunge can cost them a significant measure of cash. Indeed, even short plunges are adequate to bring about contactors on engine drives to drop out. Stoppage in a bit of procedure can pulverize the conditions for quality control of item and require restarting of generation. Therefore in this situation in which shoppers progressively request the quality power, the term power quality (PQ) achieves expanded criticalness. Transmission lines are presented to the powers of nature. Besides, every transmission line has its heap capacity confine that is regularly

controlled by either security imperatives or by warm cutoff points or by as far as possible. Despite the fact that the force quality issue is conveyance side issue, transmission lines are regularly affecting the nature of the force supplied. It is however to be noticed that while most issues connected with the transmission frameworks emerge because of the strengths of nature or because of the interconnection of force frameworks, singular clients are in charge of more significant part of the issues of force dissemination frameworks.

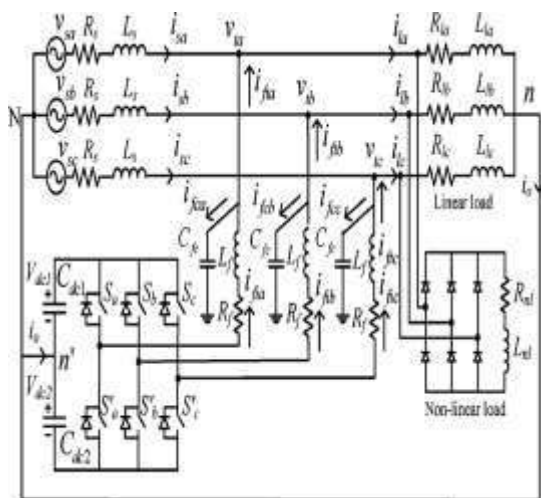

Circuit diagram of the DSTATCOM-compensated distribution system

3.0 FLEXIBLE AC TRANSMISSION SYSTEMS

Adaptable air conditioning transmission frameworks, called actualities, got in the late years a surely understood term for higher controllability in force frameworks by method for force electronic gadgets. A few actualities gadgets have been presented for different applications around the world. Various new sorts of gadgets are in the phase of being presented practically speaking.

In the vast majority of the applications the controllability is utilized to stay away from cost escalated or scene requiring augmentations of force frameworks, for occasion like redesigns or increments of substations and electrical cables. Realities gadgets give a superior adjustment to

fluctuating operational conditions and enhance the use of existing establishments. The essential utilizations of actualities gadgets are:

- Power stream control,
- Increase of transmission ability,
- Voltage control,
- Reactive force remuneration,
- Stability change,
- Power quality change,
- Power molding,
- Flicker alleviation,
- Interconnection of renewable and appropriated era and stockpiles.

Subsequently, the STATCOM sees the framework as a capacitive reactance and the STATCOM is thought to be working in an inductive mode

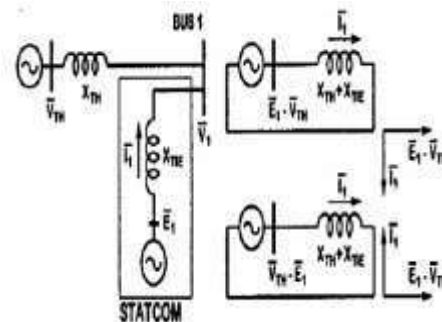

STATCOM operating in inductive or capacitive modes

4.0 MITIGATION OF POWER QUALITY PROBLEMS

In This project presents the systematic procedure of the modeling and simulation of a Distribution STATCOM (DSTATCOM) for power quality problems, voltage sag and swell based on Sinusoidal Pulse Width Modulation (SPWM) technique. Power quality is an occurrence manifested as a nonstandard voltage, current or frequency that results in a failure of end use equipments. The major problems dealt here is the voltage sag and swell. To solve this problem, custom power devices are used. One of those devices is the Distribution STATCOM (D-STATCOM), which is the most efficient and effective modern custom power device used in power distribution networks. D-STATCOM injects a current in to the system to correct the voltage sag and

swell. The control of the Voltage Source Converter (VSC) is done with the help of SPWM. The proposed D-STATCOM is modeled and simulated using MATLAB/SIMULINK software.

POWER QUALITY PROBLEMS

The force unsettling influences happen on every single electrical framework, the affectability of today's complex electronic gadgets make them more helpless to the nature of force supply. For some touchy gadgets, a flashing unsettling influence can bring about mixed information, intruded on interchanges, a solidified mouse, framework crashes and hardware disappointment and so on . A force voltage spike can harm profitable segments. Power quality issues envelop an extensive variety of unsettling influences, for example, voltage droops, swells, glimmers, consonant contortion, motivation homeless people, and intrusions.

5.0 METHODOLOGY

To upgrade the execution of conveyance framework, D-STATCOM was associated with the dissemination framework. D-STATCOM was outlined utilizing MATLAB simulink rendition R2009a.

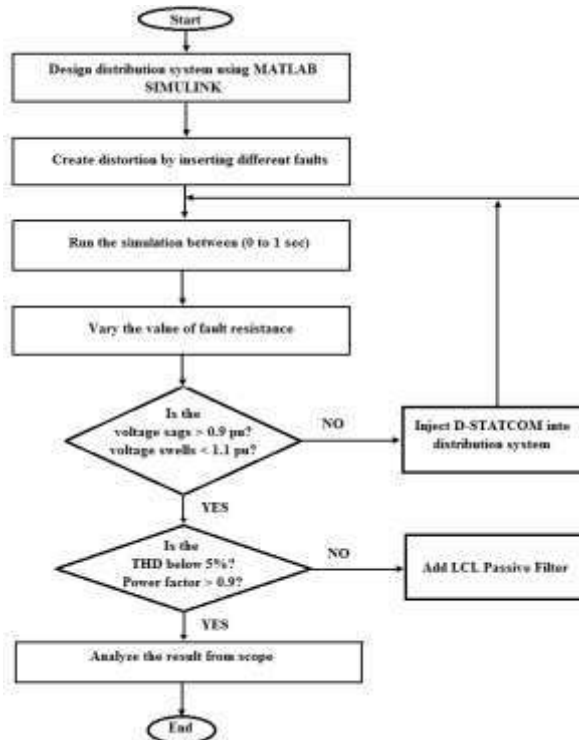

Flowchart for the Methodology

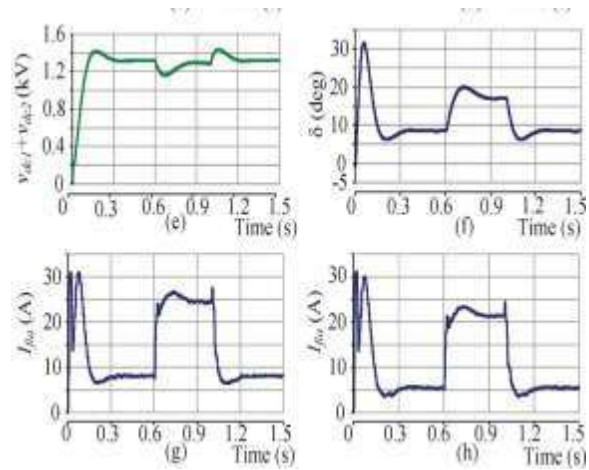

(e) Voltage at the dc bus. (f) Load angle. (g) Compensator rms current in the traditional method. (h) Compensator rms current in the proposed method.

On the off chance that the rating of VSI is restricted to relieve 20% droop, then this investment funds in rating can be utilized to moderate extra hang. To demonstrate the ability of DSTATCOM to alleviate profound droop for a more drawn out time, the source voltage is diminished to 60% of the ostensible quality for

The terminal voltages, kept up at the reference worth, are appeared in Fig. 12(b). The voltage over the dc transport is appeared in Fig. Amid drifters, this voltage veers off from its reference voltage. On the other hand, it is taken back to the reference esteem once relentless state is come to. Fig. demonstrates the stage a rms compensator current which is expansive, about 47 An, amid the list period.

These waveforms affirm that the DSTATCOM has the ability to moderate profound hang free of term. On the other hand, it requires a high current rating of the VSI.

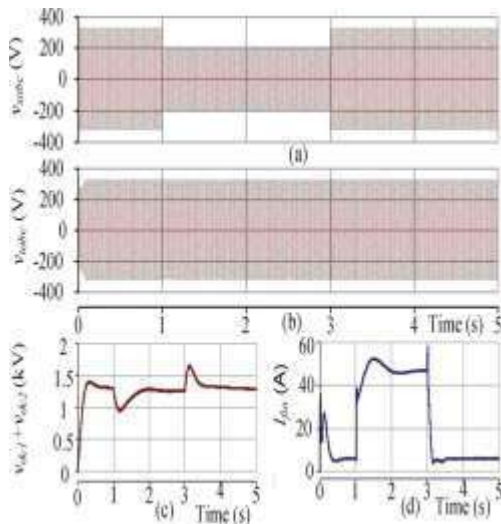
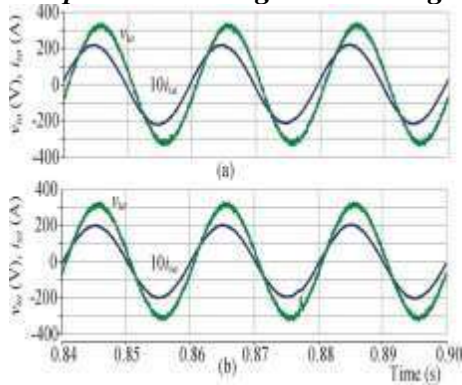

Fig. 12. (a) Source voltages. (b) Terminal voltages. (c) Voltage at the dc bus. (d) Compensator rms current in the proposed method.

C. Operation during Load Change



Terminal voltage and source current in phase- during load change.

(a) Traditional method. (b) Proposed method.

To demonstrate the effect of burden changes on framework execution, burden is expanded to 140% of its ostensible quality. Under this condition, the conventional system gives less power factor as the compensator will supply more receptive current to keep up the reference voltage. The voltage and current waveforms, as appeared in Fig. 13(a), affirm this.

In proposed system, a heap change will bring about little deviation in terminal voltage from its reference voltage. Compensator simply needs to supply additional responsive current to conquer this little additional feeder drop, thus, about UPF is kept up while controlling the

terminal voltage at its reference voltage. It is clear from Fig. 13(b).

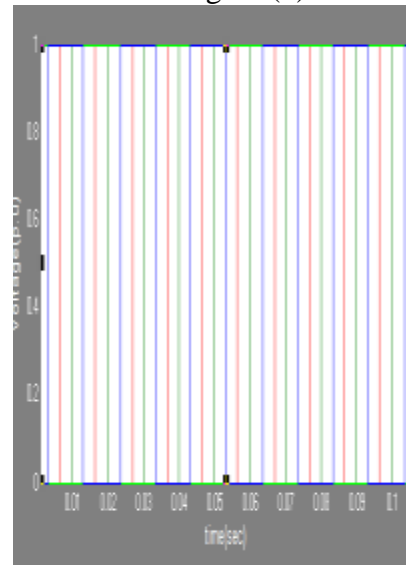

Pulses generated by PWM for VSC valves.

6.0 CONCLUSION

In this task, a control calculation has been proposed for the era of reference burden voltage for a voltage-controlled DSTATCOM. The execution of the proposed plan is contrasted and the customary voltage-controlled DSTATCOM. The proposed system gives the accompanying points of interest: 1) at ostensible burden, the compensator infuses receptive and consonant segments of burden streams, bringing about UPF; 2) almost UPF is kept up for a heap change; 3) quick voltage regulation has been accomplished amid voltage unsettling influences; and 4) misfortunes in the VSI and feeder are diminished impressively, and have higher list supporting ability with the same VSI rating contrasted with the customary plan. The recreation and test results demonstrate that the proposed plan gives DSTATCOM, a capacity to enhance a few PQ issues (identified with voltage and current).

REFERENCES

[1] El.Habrouk M., Darwish M.K, Mehta P: Active power filters-A review 2000. *Proc.IEE-Elect. Power Application*, vol.147, no.5, pp.403-413. [2] *Power Quality Survey, BSRIA, report 14419/1, may 1999.* [3] Pearson C.C, Uthayanan V: *The BSRIA power quality guide, application guide, AG/2000, July 2000.* [4] Ando I, Takahashi I, Tanaka Y, Ikehara M: *Development of high efficiency UPS having active filter ability composed of a three*

arms bridge 1997, Industrial electronics, control and instrumentation IECON 97,23RD [5] Bekiarov S.B, Emadi A: Uninterruptible power supplies: classification operation, dynamic and control. In proceeding of the 17 International conference. th [6] Tarafdat Haque M: Single phase PQ theory for active filter TENCN 02, proceeding 2002 IEEE region 10 conference on computers,communication,control and power engineering volume3,8331, Oct 2002,pp 1941-1944 IEEE applied power electronics conference, Dallas, TX, March 2002, pp.597-604. [7] Emadi A,Nasifi A, Bekiarov S B: Uninterruptible power supplies and active filters,CRC Press 2005. [8] Tarak G,Mohamed D: A hybride parallel active filter/off-line UPS unit for computer loads,electrical power quality and utilization journal, vol.XIV,no.2,2008. [9] Bradford P. Roberts,P.E: power conditioning, director of marketing S&C electric company, power quality products division [10] James J. Spangler: A power factor corrected, Mosfet, Multiple output, flyback switching supply, Motorola semiconductor products Inc, Schaumburg,Illinois.



A.pavan kumar,

B.tech(vignana bharathi institute of techonology(vbit), ghatkesar, rangareddy (district)], M.tech[anurag engineering College (autonomous), kodad, suryapet], Roll no (16c11d5409), pavankbd.tg@gmail.com



SK.Abdul pasha, Assistant professor, Anurag (Autonomous)

engineering college, Kodad. B.Tech,M.Tech JNTU Hyderabad, Ph.d pursuing from Andhra university Visakhapatnam.

Email: abdulph@gmail.com,



S CHANDRA

SEKHAR received his B.Techdegree in electrical &electronics engineering from RVR&JC college of engineering Guntur in 2001, M.Tech (high voltage engineering)degree in electrical & electronics Engineering from university college of engineering jntu kakinada in 2004 . he is pursuring Ph.D at K L university . presently he is working as associate professor and Head Of The Department of EEE. He is presented a paper on MICRO GRID FAULT ANALYSIS in WSEAS International conference at INDONESIA On 7,8,9, MAY 2016 . He is guiding aboth under graduate and post graduate student projects .his area of interest includes Micro Grids, High voltage transmission and Power systems.