

# A VECTOR CONTROLLED INDUCTION MOTOR BASED ON THE QZSDMC TOPOLOGY TO OVERCOMES THE VOLTAGE GAIN LIMITATION

**Dr. P. SANKAR BABU**  
Professor Dept. of EEE,  
SVR Engineering College,  
Nandyal  
[pscrbabu@gmail.com](mailto:pscrbabu@gmail.com)

**C.THARAKESWARA  
REDDY**  
Associate Professor Dept.  
of EEE, SVR Engineering  
College, Nandyal  
[tharakreddyc@gmail.com](mailto:tharakreddyc@gmail.com)

**P. ILIYAS**  
PG-Scholar, Dept. of EEE,  
SVR Engineering College,  
Nandyal  
[iliyas203eee@gmail.com](mailto:iliyas203eee@gmail.com)

## ABSTRACT

*This paper proposes a novel four-quadrant vector controlled induction motor (IM) adjustable speed drive (ASD) system based on a recently proposed matrix converter topology called quasi-Z-source direct matrix converter (QZSDMC). The QZSDMC is formed by cascading the quasi-Z-source impedance network and the conventional direct matrix converter (DMC). The QZSDMC can provide buck-boost operation with voltage transfer ratio controlled by controlling the shoot-through duty ratio and bidirectional operation capability. The control strategy, which is based on the indirect field oriented control algorithm, is able to control the motor speed from zero to the rated value under full load condition during motoring and regenerating operation modes. The operating principle of the proposed system is presented in detail. The simulation and the real-time implementation results, using dSPACE 1103 ControlDesk, validate the high performance of the proposed four-quadrants IM-ASD based on QZSDMC system. The proposed four-quadrant vector controlled IM-ASD system based on the QZSDMC topology overcomes the voltage gain limitation of the traditional DMC and achieves buck and boost condition in four-quadrant modes with reduced number of switches, therefore achieving low cost, high efficiency, and reliability, compared with back-to-back converter.*

**Keywords:** Direct matrix converter (DMC), indirect field oriented control (IFOC), induction motor (IM), quasi-Z-source converter (QZSC), quasi-Z-source DMC (QZSDMC), Z-source converter (ZSC).

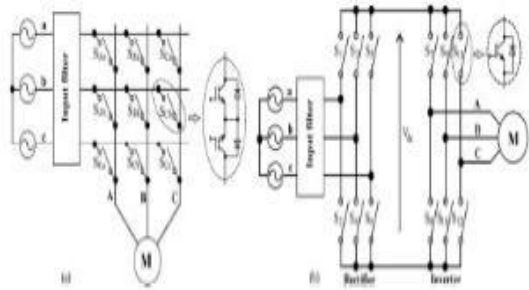
## 1. INTRODUCTION

THE use of variable speed motor drives is a growing trend in industrial and automotive applications, guaranteeing high efficiency,

increased energy saving, and higher versatility and flexibility [1]. The back-to-back converter, which is formed by tying two VSI bridges together at their shared dc-link, is commonly applied in many motor drive applications. One of the converters operates in the rectifying mode, while the other converter operates in the inverting mode. The dc-link voltage must be higher than the peak line-to-line voltage to achieve full control of the motor torque [2], [3]. Despite being a well-proven topology, the back-to-back converter still has limitations since it requires a large capacitor in the dc-link and a heavy filter inductor at the input terminals.

The dc-link capacitor is a critical component, especially in high-power or high-voltage applications, since it is large and expensive component. Further, it has a limited service lifetime, and is well known to be a primary source of failure in most of the converters [4]. The source-side inductors are also a burden to the system; their size is typically 20%–40% of the system size when operating at a switching frequency of several kilohertz. Furthermore, the back-to-back topology is sensitive toward electromagnetic interference and other sources of noises that can accidentally turn ON two switches from the same phase leg, causing a

short circuit fault in turn. Thus, the drawbacks of conventional back-to-back converters are high cost, large size, heavy weight, relatively high energy losses, and sensitivity toward electromagnetic interference [3].



**Fig. 1 (a) DMC and (b) IMC topology**

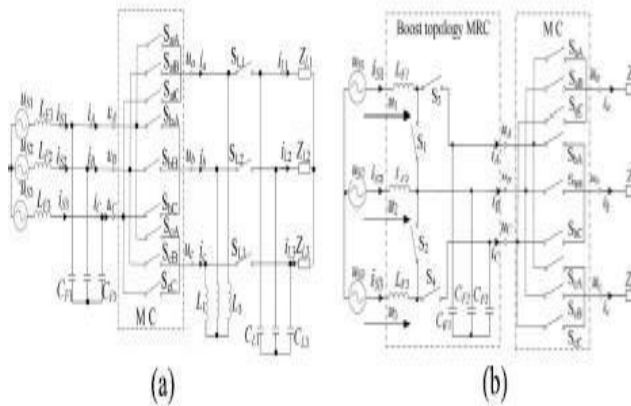
The matrix converter is an attractive alternative to the back to back converter because it can convert an ac voltage directly into an ac output voltage of variable amplitude and frequency without the need for an intermediate dc-link and capacitor. Furthermore, it provides bidirectional power flow, sinusoidal input/output currents, controllable input power factor, and has compact design. The volume savings of a matrix converter compared with a back-to-back converter has been estimated to be a factor of three [3]. The large dc-link capacitor and large input inductors of the back-to-back converter are replaced by small input filter with capacitors and inductors in the matrix converter. Furthermore, because of a high integration capability and higher reliability of the semiconductor devices, the matrix converter topology is a better solution for extreme temperatures and critical volume/weight applications [5]. Matrix converters can be divided into two categories: the DMC and IMC, as shown in Fig. 1. The DMC performs the voltage and current conversion in one stage (direct) power conversion while the IMC features a two-stage (indirect) power conversion. The DMC and IMC circuit topologies are equivalent

in their basic functionality. The difference in the categories results from a difference in loading of the semiconductors and a different commutation scheme.

The IMC has a simpler commutation due to its two-stage structure; however, this is achieved at the expense of more series connected power devices in the current path, which results in higher semiconductor losses and typically a lower achievable efficiency compared with the DMC. However, the differences between the control performances of DMC and IMC are quite negligible in practice. Therefore, the DMC will be investigated within this paper as a candidate topology to achieve highest conversion efficiency [6]. For all these attractive properties, the matrix converter has not yet gained much attention in the industry due to its several unsolved problems. The most critical problem is the reduced voltage transfer ratio, which is defined as the ratio between the output and the input voltages, and has been constrained to 0.866 when using linear modulation [5]. Several researches on the over modulation have been carried out to overcome the problem of low voltage transfer ratio. However, the over modulation can only be achieved at the expense of the quality of both output voltage and input current [7].

Improving the voltage transfer ratio is an important research topic. One easy solution is to connect a transformer between the power supply and the MC. However, the mains frequency transformer is bulky, expensive, and affects the system efficiency. Other solution is to use a MRFC, which consists of a MC and a ac chopper, and has a voltage transfer ratio greater than one. The MRFC converter is categorized into two groups: the integrated and cascade MRFCs, as shown in Fig. 2 [8]. Unfortunately, the IMRFC typology has several disadvantages. First, the control algorithm is complicated due to the

required synchronization between the MC and the ac chopper. Second, the voltage transfer ratio strongly depends on the circuit and the load parameters. Finally, the input power factor is lower than other MCs even for a purely resistive load. The CMRFC topology has less passive components compared by the IMRFC topology; however, it has limited voltage gain, complicated damping control of the input current and disturbed output current.



**Fig. 2. (a) IMRFC and (b) CMRFC topologies**

The ZSC, as shown in Fig. 3(a), is an innovative power electronics converter technology presented recently. It employs a unique impedance network to couple the main circuit of the converter to the power source. With proper control, the ZSC can buck or boost voltages to a desired magnitude, which might be greater than the available dc input voltage. The ZSC uses the ST state, turning ON two switches from the same phase leg, to boost the input voltage. Therefore, the ST state now is one of the converter's normal operating states and no longer a potential danger for the circuit; in addition, there is no requirement of the dead time with the ZSC, hence reliability of the system is improved [9].

The basic ZSC topology has some significant drawbacks, namely that the input current is discontinuous in the boost mode and the Z-network capacitors must sustain high voltage.

Discontinuous input current is prohibited for many sources and requires large input filters. To a great extent, this shortcoming is avoided in the QZSC, as shown Fig. 3(b), by the presence of an input coil in the QZSC that buffers the source current. Moreover, voltage on one of the Z-network capacitors is lower than in case of the basic ZSC topology. In addition, it is also possible to develop joint grounding of the input power source and the dc-link bus, which reduce the common mode noise. Hence, the QZSC topology has no disadvantages when compared with the traditional ZSC topology. The QZSC topology therefore can be used in any application in which the basic ZSC topology would be used [10]. Therefore, by introducing the Z-source network to the conventional MC, which was recently proposed as ZSDMC, as shown in Fig. 4 [11]–[13], it is possible to overcome the low voltage gain of the traditional MC; in addition, the Z-source network allows the short circuit, which makes the ZSDMC commutation easier. The ZSDMC is derived from the traditional DMC by only adding three inductors, capacitors, switches, and diodes. However, the ZSDMC has a limited voltage boost ratio (voltage gain can only reach 1.15), inherited phase shift caused by the Z-network, which makes the control inaccurate, and also discontinuous current in the front of Z-source network. However, for the QZSDMC, as shown in Fig. 5, the voltage gain can go to four to five times or even higher depending on the voltage rating of the switches, no phase shift, which can cause less error in the control, and lower switch voltage and current stress [14]. In addition, the circuit in Fig. 5(b) has continuous input current [1].

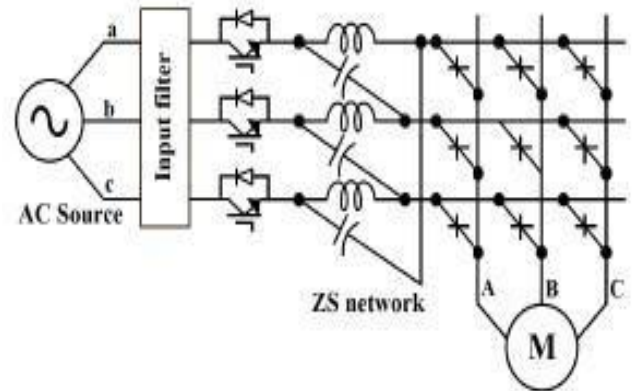
Compared with traditional DMC, ZSDMC and QZSDMC both can boost voltage higher than 0.866. The boost ratio depends on the duty cycle of extra ST state. Also, the QZSDMC topology can conduct less voltage/current

stress on the switch and passives, less input and output harmonics and higher power factor than the ZSDMC. Moreover, compared with ZSDMC topology, the QZSDMC is a component less,

size compact, high efficient, and a wide range buck-boost matrix converter [6].

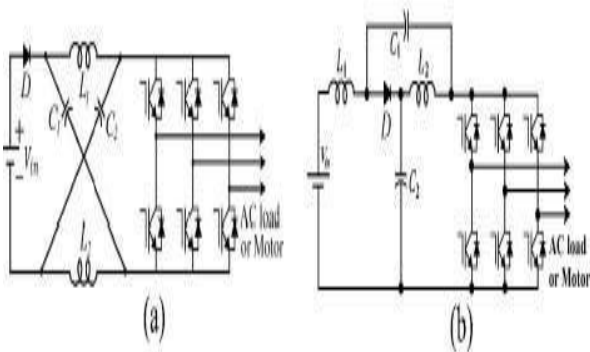
Nowadays, IM are widely used in industry due to their reliability, robustness, high efficiency, and ability to operate in wide torque and velocity ranges. To achieve high dynamic performance in an IM drive application, vector control is often applied. Vector control makes ac drives behave like dc drives by independently controlling the flux and the torque of the ac motor. Therefore, the field oriented control is used in the design of IM drives in high-performance applications. The main idea of the field oriented control is to control of the torque and the flux separately. IFOC is one of the most effective vector control of IMs due to the simplicity of designing and construction [7]–[14].

desired ac output voltage, even greater than the input line voltage due to its boost voltage capability. The four-quadrant speed control is implemented using the IFOC during motoring and regenerating operation modes. The system's configuration, equivalent circuit, analysis, and control are presented in detail. Simulation and dSPACE real time implementation results demonstrate the high performance of the proposed four-quadrants QZSDMC-IM-based ASD system.



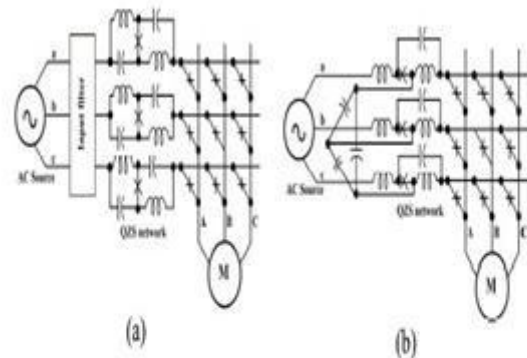
**Fig. 4. Voltage fed ZSDMC topology**

### IMPLEMENTATION

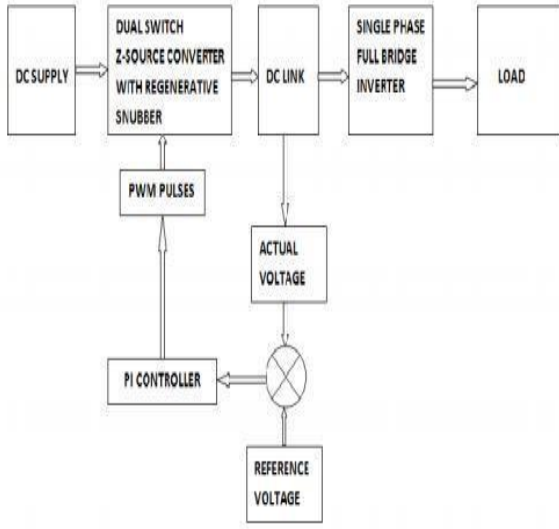


**Fig. 3. (a) Basic ZSC and (b) QZSC structures.**

In this paper, the application of the QZSDMC topology for four-quadrant IM-ASD system is proposed. The QZSDMC can produce the



**Fig. 5. Voltage fed QZSDMC topologies with (a) discontinuous and (b) continuous input current.**



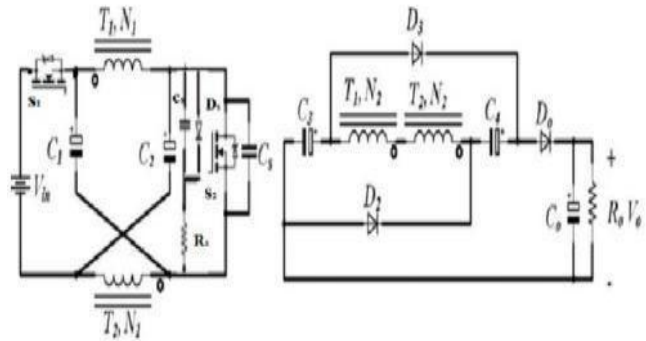
**Fig 6: Block diagram of proposed system**

Fig 6 illustrates the schematic diagram of the proposed system. From the Fig 6, it is seen that the dual switch Z-Source Converter is connected with the full bridge inverter. The DC link capacitor is placed in between the converter and inverter. The regenerative snubber circuit is used to avoid voltage stress and switching loss by reducing leakage inductance. The inverter is used to control the transit power is controlled across the DLink to maintain voltage constant. This converted AC voltage given to run an Induction Motor. Also using the PI controller, voltage of the load can be maintained. The PI controller tunes the converter circuit to maintain a constant input voltage to the inverter by producing corresponding pulses. The brief discussion of Fig 6 is as follows.

**Dual switch z-source converter:**

The Z-Source Converter unit has its own impedance network which has boosting capacity. The existing single switch Z-Source Converter has drawbacks of reverse recovery of diode current, leakage inductance leads to high voltage spike and switching loss. The proposed dual switch Z-Source Converter has the replacement of diode by MOSFET switch. Here, there is no

problem of reverse recovery of diode. The duty cycle of the switches are controlled here so that the level of the input for the converter can be decided. The proposed topology has no dead time of switching loss. Due to leakage inductance of the impedance network results in high voltage spike during switch transition. The leakage inductance can be reduced by raising its current level up so that it reduces their current difference and which in turn reduces voltage spike too.



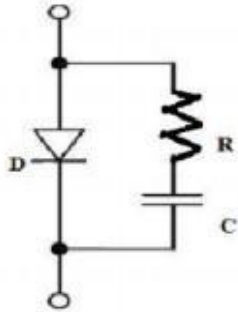
**Fig 7 Circuit diagram of the proposed converter**

**REGENERATIVE SNUBBER**

The snubber circuit is kept across the switch to reduce voltage stress. The capacitance of the snubber capacitor should be chosen as small as possible (to minimize conduction losses in the auxiliary components) but still large enough to slow down the voltage rise across the main switch to the extent that the turn-off losses are significantly reduced in Fig 8.

The snubber circuit not only reduces the voltage spikes but also relieves the high voltage and high current stresses inflict on switches at both turn on and turn off. The snubber design is the last step in the power stage design and is attempted after the values of other circuit parameters were obtained. One possible design approach is as follows. As a first pass design, choose a switch with a reasonable maximum voltage for a given

application. Result in lowest maximum snubber capacitor voltage.



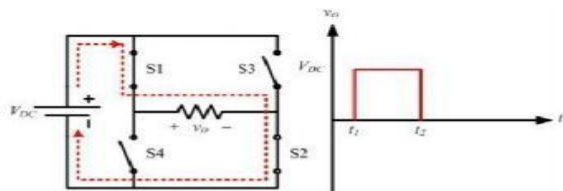
**Fig 8 Regenerative snubber**

**DC LINK**

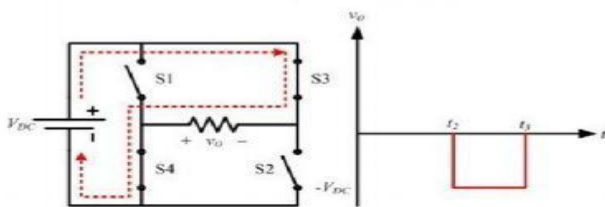
DC link is used to reduce ripples from DC output voltage and supplies ripple free DC as input to the full bridge inverter.

**SINGLE PHASE INVERTER**

A single phase full bridge inverter has four switches which are connected to the load. When transistors S1 and S2 are turned on simultaneously, the positive voltage  $V_s$  appears across the load. When Switches S3 and S4 are turned on, the voltage across the load is reversed and is  $-V_s$ . The rms output voltage can be found from, A single phase full bridge circuit has peak reverse blocking voltage of each switch and the quality of output voltage as same as half bridge circuit.



**Fig 4 Mode I operation**

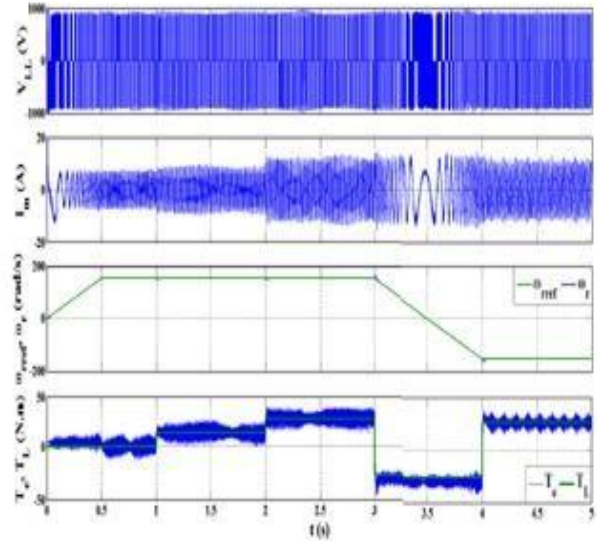


**Fig 9 Mode II operation**

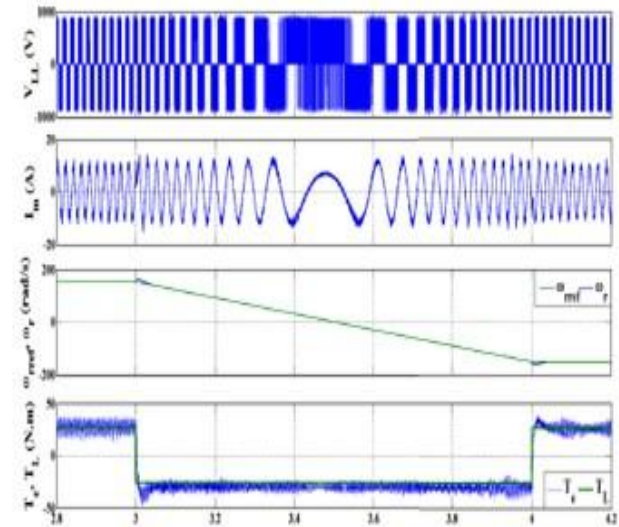
**EXPERIMENTAL WORK**

**MATLAB Simulation Results:**

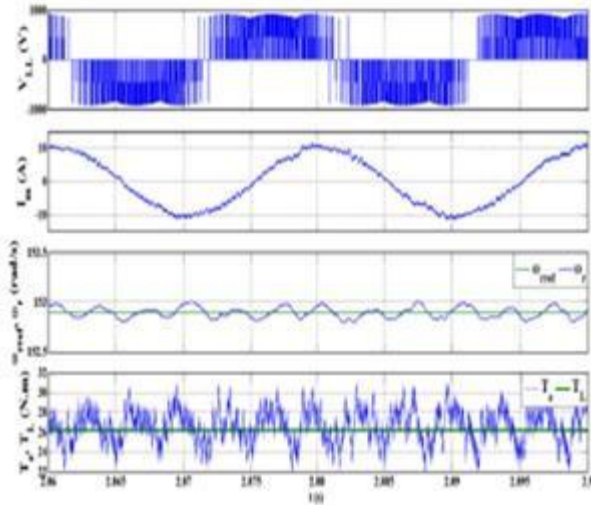
To verify the proposed QZSDMC-IM drive system performance, simulations are carried out using MATLAB/SIMULINK software for a 4-kW IM using the parameters. The QZSDMC-IM ASD system simulating model is



**Fig. 10. Motor response during motoring and regenerating operation modes**



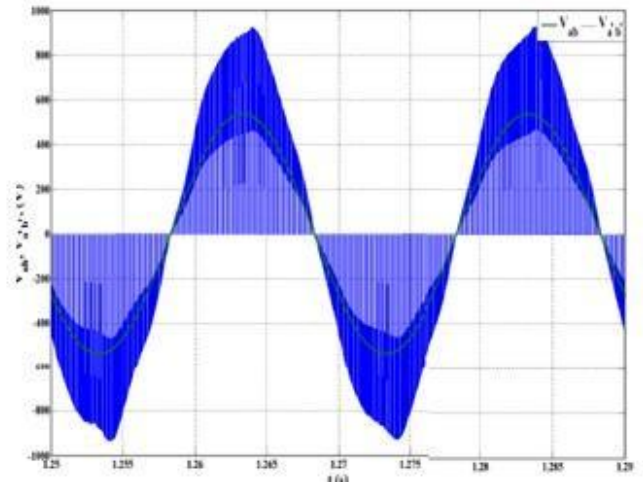
**Fig. 11. Motor response during speed reverses**



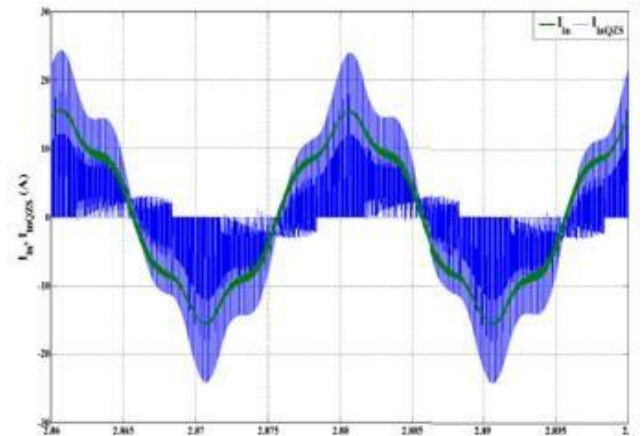
**Fig. 12. Steady-state motor current and voltage waveforms during motoring at rated conditions.**

Tested during the motoring and regenerating operation modes, as shown in Fig. 14: the acceleration mode at no load during the time interval 0–1 s; the steady-state operation mode with half the rated load torque and the rated speed during the time interval 1–2 s; the steady-state operation mode with the rated load torque and the rated speed during the time interval 2–3s; the deceleration mode from the rated speed to negative the rated speed with negative the rated torque during time interval 3–4 s; and the regeneration mode with the rated load and negative the rated speed during the time interval 4–5s. Fig. 15 shows the system ability to perfectly track the speed and load torque references during different operation modes. Also, Fig. 12 shows the motor response during speed reverse, where, the motor speed tracks its reference and the motor current and voltage waveforms are reversed. Fig. 13 shows the steady-state motor response during motoring operation at rated conditions. The given ST duty ratio  $D$  is 0.1. According to (4) and (6), one can get the boost factor  $B$  of 1.25 and the maximum value of voltage gain  $G$  is 1.125. Fig. 13 shows

the output line voltage amplitude (around 670 V) of QZS-network, which is



**Fig. 13. Input and output line-to-line voltage of the QZS-network**



**Fig. 14. Input and output current of the QZS-network**

### CONCLUSION

This paper proposed a new four-quadrant vector controlled IM ASD system based on the QZSDMC topology. The proposed system overcomes the reduced voltage transfer ratio limitations of traditional DMC-based ASD system, therefore, the proposed QZSDMC-IM- based ASD will increase the application of the DMC in different industry fields the proposed ASD system can operate at full load with small QZSnetwork elements. The QZSDMC can achieve buck and boost



operation with reduced number of switches needed, therefore achieving low cost, high efficiency, and reliability, compared with the traditional DMCs, in addition, there is no requirement of dead time with QZS-network, hence commutation of the QZSDMC is easier than the traditional DMC. The proposed ASD system can provide a voltage gain larger than one and can operate in motoring and regenerating operation modes with perfect references tracking as verified by MATLAB simulation and dSPACE real-time implementation results.

## REFERENCES

- [1] J. D. van Wyk and F. C. Lee, "On a future for power electronics," *IEEE J. Emerging Sel. Topics Power Electron.*, vol. 1, no. 2, pp. 59–72, Jun. 2013.
- [2] S. Bhowmik and R. Spee, "A guide to the application-oriented selection of AC/AC converter topologies," *IEEE Trans. Power Electron.*, vol. 8, no. 2, pp. 156–163, Apr. 1993.
- [3] T. Friedli, J. W. Kolar, J. Rodriguez, and P. W. Wheeler, "Comparative evaluation of three-phase AC-AC matrix converter and voltage DC-link back-to-back converter systems," *IEEE Trans. Ind. Electron.*, vol. 59, no. 12, pp. 4487–4510, Dec. 2012.
- [4] S. K. Maddula and J. C. Balda, "Lifetime of electrolytic capacitors in regenerative induction motor drives," in *Proc. IEEE Power Electron. Specialists Conf.*, Jun. 2005, pp. 153–159.
- [5] P. W. Wheeler, J. Rodriguez, J. C. Clare, and L. Empringham, "Matrix converters: A technology review," *IEEE Trans. Ind. Electron.*, vol. 49, no. 2, pp. 274–288, Apr. 2002.
- [6] M. Jussila and H. Tuusa, "Comparison of direct and indirect matrix converters in induction motor drive," in *Proc. 32nd Annu. Conf. IEEE Ind. Electron.*, Nov. 2006, pp. 1621–1626.
- [7] Y. D. Yoon and S. K. Sul, "Carrier-based modulation technique for matrix converter," *IEEE Trans. Power Electron.*, vol. 21, no. 6, pp. 1691–1703, Nov. 2006.
- [8] P. Szczeńiak, *Three-phase AC-AC Power Converters Based on Matrix Converter Topology, Matrix-reactance*

*frequency converters concept.* New York, NY, USA: Springer-Verlag, 2013.

[9] F. Z. Peng, "Z-source inverter," *IEEE Trans. Ind. Appl.*, vol. 39, no. 2, pp. 504–510, Mar./Apr. 2003.

[10] J. Anderson and F. Z. Peng, "Four quasi-Z-source inverters," in *Proc. 39th IEEE PESC*, Jun. 2008, pp. 2743–2749.

[11] K. Park, S.-T. Jou, and K.-B. Lee, "Z-source matrix converter with unity voltage transfer ratio," in *Proc. 35th IEEE IECON*, Porto, Portugal, Nov. 2009, pp. 4523–4528.

[12] B. Ge, Q. Lei, W. Qian, and F. Z. Peng, "A family of Z-source matrix converters," *IEEE Trans. Ind. Electron.*, vol. 59, no. 1, pp. 35–46, Jan. 2012.

[13] S. Liu, B. Ge, H. Abu-Rub, F. Zheng Peng, and Y. Liu, "Quasi-Z-source matrix converter based induction motor drives," in *Proc. 38th Annu. Conf. IEEE IECON*, Montreal, QC, Canada, Oct. 2012, pp. 5303–5307.

[14] Q. Lei, F. Z. Peng, and B. Ge, "Pulse-width-amplitude-modulated voltage-fed quasi-Z-source direct matrix converter with maximum constant boost," in *Proc. 27th Annu. IEEE APEC*, Feb. 2012, pp. 641–646.