

AN IMPROVED IUPQC CONTROLLER TO PROVIDE GRID VOLTAGE REGULATION BY USING FUZZY LOGIC CONTROLLER

V. YOGANANDAM

PG Scholar, Dept of EEE,
Amalapuram Institute of
Management Sciences &
College of Engineering

K. MUNI PRATAP

Assoc. professor Dept of EEE,
Amalapuram institute of
management sciences &
college of engineering

D. MOHAN REDDY

Professor & Principal,
Amalapuram Institute of
Management Sciences and College
of Engineering,
Mummidivaram, East Godavari
District, Andhra Pradesh, India

ABSTRACT:

This paper introduces another control for a double topology of Unified Power Quality Conditioner (iUPQC) to enhance the power quality by giving voltage direction at jackpot side transport and in addition lattice side transport in a conveyance framework. An improved Fuzzy rationale controller is utilized for the double topology of the bound together power quality conditioner (iUPQC) extending its congruity in control quality remuneration, and moreover in smaller scale framework applications. In this paper the enhanced iUPQC controller gives the functionalities of both STATCOM and UPQC. the similar investigation of a few control methodologies bolstered UPQC for control quality change highlights is exhibited. By utilizing Fuzzy rationale controller we have a similar working of iUPQC with PI control and also the sounds are diminished. Reenactments comes about are given three stage diode rectifier load and two stage diode rectifier stack by utilizing MATLAB/SIMULINK programming.

Index Terms: UPQC, iUPQC, STATCOM, DSTATCOM, DVR, Fuzzy logic controller, Voltage sag/swell, Voltage regulation.

I. INTRODUCTION

Due to the utilization of number of electronic parts in enterprises, homes and so forth, these gadgets require top notch vitality to work legitimately. In the meantime these are the most in charge of infusion of voltage droops, swells, sounds and other related aggravation in the conveyance framework. Voltage Source Converter based custom power gadgets are progressively being utilized as a part of custom-control applications for enhancing the power quality (PQ) of energy dissemination frameworks. Gadgets, for

example, conveyance static compensator (DSTATCOM) and dynamic voltage restorer (DVR) have just been examined widely in [10]. A DSTATCOM can remunerate the mutilation and unbalance because of symmetrical and hilter kilter blames in a heap with the end goal that an adjusted sinusoidal current course through the feeder [1]. It can likewise direct the voltage of a dissemination bus [3], [4]. A DVR can remunerate the voltage droop/swell and twisting in the supply side voltage with the end goal that the voltage over a delicate/basic load terminal is superbly controlled An Interline bound together power-quality conditioner (iUPQC) can play out the elements of both DSTATCOM.

Furthermore, DVR [7], [8] The IUPQC comprises of two voltage-source converters (VSCs) that are associated with a typical dc transport. One of the VSCs is associated in arrangement with a circulation feeder, while the other one is associated in shunt with a similar feeder. In [9], a setup called IDVR has been talked about in which two DVRs are associated in arrangement with two separate adjoining feeders. The dc transports of the DVRs are associated together. The DVR assimilates genuine power from one feeder and keeps up the dc interface voltage to relieve 90% (around 0.1 p.u.) voltage hang in the other feeder with adjusted burdens associated in the appropriation framework. It is additionally conceivable to interface two shunt VSCs to various feeders through a typical dc connect. The

IUPQC comprises of two voltage source converters (VSCs) that are associated with a typical dc transport.

Another association for an IUPQC with Fuzzy Logic Controller to diminish the THD significantly contrasted with traditional PI controller based voltage source converters. Two feeders, Feeder-1 and Feeder2, which are associated with two unique substations, supply the framework loads L-1 and L-2. The supply voltages are meant by V_{s1} and V_{s2} [1]. It is expected that the IUPQC is associated with two transports B-1 and B-2, the voltages of which are signified by V_{t1} and V_{t2} individually. Encourage two feeder streams are indicated by $is1$ and $is2$ while the heap ebbs and flows are signified by $il1$ and $il2$. The heap L-2 voltage is indicated by V_{t2} . The motivation behind the IUPQC is to hold the voltages V_{t1} and V_{t2} consistent against voltage hang, swell, issues and sounds in both of the two feeders. It has been shown that the IUPQC can ingest control from one feeder (say Feeder-1) to Hold V_{t2} consistent if there should be an occurrence of a hang in the voltage V_{s2} . This can be proficient as the two VSC's are provided by a typical dc capacitor. The dc capacitor voltage control has been talked about here alongside voltage reference era system. Likewise, the cutoff points of achievable execution have been figured.

This paper is organized in five sections. After this introduction, in Section II, the system model has explained. Section III presents the proposed controller and fuzzy logic controller. Finally, Sections IV and V provide the simulation results and the conclusions, respectively.

II. SYSTEM MODEL

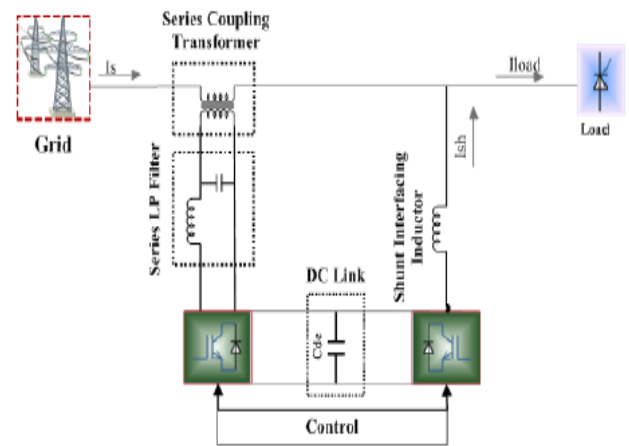

Fig.1 applicability of iUPQC.

Fig. 1 depicts an electrical system with two buses in spotlight, i.e., bus A and bus B. Bus A is a critical bus of the power system that supplies sensitive loads and serves as point of coupling of a micro grid. Bus B is a bus of the micro grid, where sensitive loads are connected, which requires premium-quality power supply. The voltages at buses A and B must be regulated, in order to properly supply the sensitive loads and the nonlinear loads. The effects caused by the harmonic currents drawn by the nonlinear loads should be mitigated, avoiding harmonic voltage propagation to bus A. The use of a STATCOM to guarantee the voltage regulation at bus A is not enough because the harmonic currents drawn by the nonlinear loads are not mitigated. On the other hand, a UPQC or an iUPQC between bus A and bus B can compensate the harmonic currents of the nonlinear loads and compensate the voltage at bus B, in terms of voltage harmonics, unbalance, and sag/swell. Nevertheless, this is still not enough to guarantee the voltage regulation at bus A. Hence, to achieve all the desired goals, a STATCOM at bus A and a UPQC (or an iUPQC) between buses A and B should be employed. However, the costs of this solution would be unreasonably high. An attractive solution would be the use of a modified iUPQC controller to provide also reactive power support to bus A, in addition to all those functionalities of this equipment, as

presented in [9] and [11]. Note that the modified iUPQC serves as an intertie between buses A and B. Moreover, the micro grid connected to the bus B could be a complex system comprising distributed generation, energy management system, and other control systems involving micro grid, as well as smart grid concepts [12]. In summary, the modified iUPQC can provide the following functionalities:

- a) "Smart" circuit breaker as an intertie between the grid and the micro grid;
- b) Energy and power flow control between the grid and the micro grid (imposed by a tertiary control layer for the micro grid);
- c) Reactive power support at bus A of the power system;
- d) Voltage/frequency support at bus B of the micro grid;
- e) Harmonic voltage and current isolation between bus A and bus B (simultaneous grid-voltage and load-current active filtering capability);
- f) Voltage and current imbalance compensation.

The functionalities (d)–(f) previously listed were extensively explained and verified through simulations and experimental analysis, whereas the functionality (c) comprises the original contribution of the present work. Fig. 2 depicts, in detail, the connections and measurements of the iUPQC between bus A and bus B. Fig.3 has the equivalent circuit of the system. According to the conventional iUPQC controller, the shunt converter imposes a controlled sinusoidal voltage at bus B, which corresponds to the functionality (d). As a result, the shunt converter has no further degree of freedom in terms of compensating active- or reactive-power variables to expand its functionality. On the other hand, the series converter of a conventional iUPQC uses only an active-power control variable p , in order to synthesize a fundamental sinusoidal current drawn from bus A, corresponding to the active power demanded by bus B. If the dc link of the iUPQC

has no large energy storage system or even no energy source, the control variable p also serves as an additional active-power reference to the series converter to keep the energy inside the dc link of the iUPQC balanced. In this case, the losses in the iUPQC and the active power supplied by the shunt converter must be quickly compensated in the form of an additional active power injected by the series converter into the bus B. The iUPQC can serve as:

- a) "Smart" circuit breaker and as
- b) power flow controller between the grid and the micro grid only if the compensating active- and reactive-power references of the series converter can be set arbitrarily.

In this case, it is necessary to provide an energy source (or large energy storage) associated to the dc link of the iUPQC. The last degree of freedom is represented by a reactive-power control variable q for the series converter of the iUPQC. In this way, the iUPQC will provide reactive-power compensation like a STATCOM to the bus A of the grid. As it will be confirmed, this functionality can be added into the controller without degrading all other functionalities of the iUPQC.

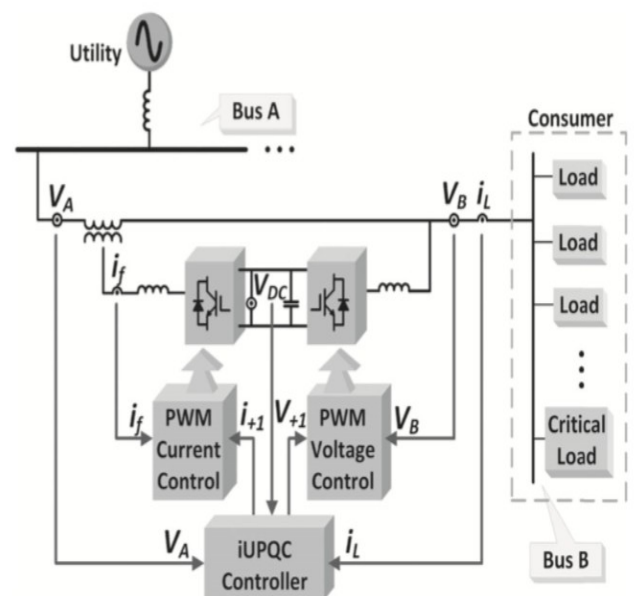

Fig. 2 Proposed iUPQC configuration.

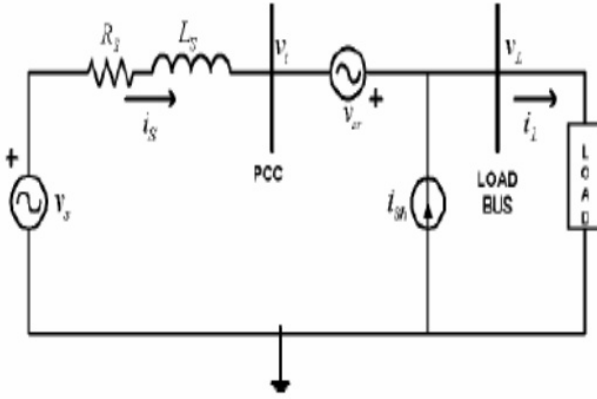

Fig.3 Equivalent circuit of proposed iUPQC configuration

III. CONTROLLER HIERARCHY

3.1. Main Controller

In above chapter Fig. 2 depicts the iUPQC and the measured units of a three-phase three-wire system that are used in the controller. Fig. 3 shows the proposed controller. The controller inputs are the voltages at buses A and B, the current demanded by bus B (i_L), and the voltage V_{DC} of the common dc link. The outputs are the shunt-voltage reference and the series-current reference to the pulse width modulation (PWM) controllers. The voltage and current PWM controllers can be as simple as those employed in [13], or be improved further to better deal with voltage and current imbalance and harmonics [15]. First, the simplified Clark transformation is applied to the measured variables. As example of this transformation, the grid voltage in the $\alpha\beta$ -reference frame can be calculated as

$$\begin{bmatrix} V_{A_\alpha} \\ V_{A_\beta} \end{bmatrix} = \begin{bmatrix} 1 & \frac{1}{2} \\ 0 & \frac{\sqrt{3}}{2} \end{bmatrix} \begin{bmatrix} V_{A_{ab}} \\ V_{A_{bc}} \end{bmatrix} \quad (1)$$

The shunt converter imposes the voltage at bus B. Thus, it is necessary to synthesize sinusoidal voltages with nominal amplitude and frequency. Consequently, the signals sent to the PWM controller are the phase-locked loop (PLL) outputs with amplitude equal to 1 p.u. There are many possible PLL algorithms, which could be used in

this case, as verified in the original iUPQC approach as presented in [14], the shunt-converter voltage reference can be either the PLL outputs or the fundamental positive-sequence component V_{A+1} of the grid voltage (bus A in Fig. 2). The use of V_{A+1} in the controller is useful to minimize the circulating power through the series and shunt converters, under normal operation, while the amplitude of the grid voltage is within an acceptable range of magnitude. However, this is not the case here, in the modified iUPQC controller, since now the grid voltage will be also regulated by the modified iUPQC. In other words, both buses will be regulated independently to track their reference values. The series converter synthesizes the current drawn from the grid bus (bus A). In the original approach of iUPQC, this current is calculated through the average active power required by the loads P_L plus the power P_{Loss} . The load active power can be estimated by

$$P_L = V_{+1_\alpha} * i_{L_\alpha} + V_{+1_\beta} * i_{L_\beta} \quad (2)$$

Where i_{L_α} , i_{L_β} are the load currents, and V_{+1_α} , V_{+1_β} are the voltage references for the shunt converter. A low-pass filter is used to obtain the average active power (P_L). The losses in the power converters and the circulating power to provide energy balance inside the iUPQC are calculated indirectly from the measurement of the dc-link voltage. In other words, the power signal P_{Loss} is determined by a proportional– integral (PI) controller (PI block in Fig. 3), by comparing the measured dc voltage V_{DC} with its reference value. The additional control loop to provide voltage regulation like a STATCOM at the grid bus is represented by the control signal QSTATCOM in Fig. 3. This control signal is obtained through a PI controller, in which the input variable is the error between the reference value and the actual aggregate voltage of the grid bus, given by

$$V_{col} = \sqrt{V_{A+1_\alpha}^2 + V_{B+1_\alpha}^2} \quad (3)$$

The sum of the power signals P_L and P_{Loss} composes the active-power control variable for the series converter of the iUPQC (p) described in Section II. Likewise, QSTATCOM is the reactive-power control variable (q). Thus, the current references $i_{+1\alpha}$ and $i_{+1\beta}$ of the series converter are determined by

$$\begin{bmatrix} i_{+1\alpha} \\ i_{+1\beta} \end{bmatrix} = \frac{1}{V_{A+1\alpha}^2 + V_{B+1\alpha}^2} \begin{bmatrix} V_{A+1\alpha} & V_{A+1\beta} \\ V_{A+1\beta} & -V_{A+1\alpha} \end{bmatrix} X \begin{bmatrix} P_L + P_{Loss} \\ Q_{STATCOM} \end{bmatrix} \quad (4)$$

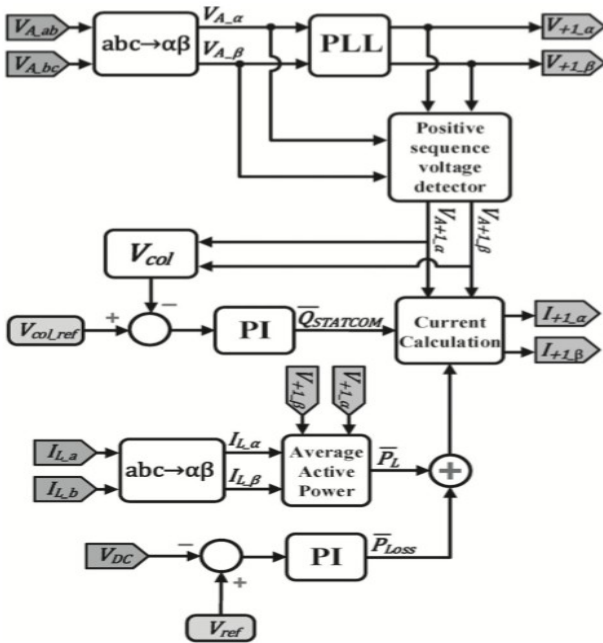

Fig. 3 Novel iUPQC controller.

3.2 Fuzzy Logic Control

Fuzzy Logic controllers are a smart choice when exact mathematical formulations are tedious. The construction of the rules requires a detailed understanding of the system to be controlled. The FL controller which can be characterized as follows: 7 linguistic variables for Error, 7 linguistic variables for Derivative Error are two inputs and 7 linguistic variables for output. Triangular membership functions for Error

& Derivative error in terms of voltages and triangular membership functions for output variables are considered. A rule base of 49 rules is selected to establish the fuzzy controller [14]. With the use of Mamdani's implication and with de-fuzzification by a centroid method, the FL controller provides the switching function to carry out best control action and each rule expresses an operating condition in the system. In this paper, the error in terms of voltage (V_d) and the derivative of error in terms of voltage (ΔV_d) are considered as the inputs of the first FL controller and the error in terms of voltage (V_q) and the derivative of error in terms of voltage (ΔV_q) as the inputs of the second FL controller. The reference voltages for the voltage regulator are the voltages V_{dref} and V_{qref} . The FL controller consists of 7 linguistic variables from Error which are as negative big (NB), negative medium (NM), negative small (NS), zero (ZE), positive small (PS), positive medium (PM) and positive big (PB). For derivative error are same 7 linguistic variables as negative big (NB), negative medium (NM), negative small (NS), zero (ZE), positive small (PS), positive medium (PM) and positive big (PB). The membership functions of the inputs are illustrated in Fig 4 and Fig 5.

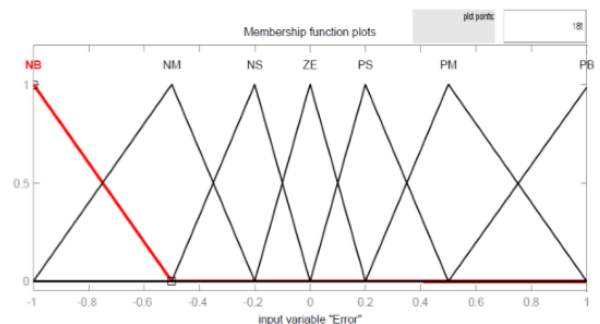

Fig.4 Membership Function of Error

In de-fuzzification process, there are 7 linguistic variables through which Error and Error-rate are defined by these linguistic variables such as negative big (NB), negative medium (NM), negative small (NS), zero (ZE), positive small (PS), positive medium (PM) and positive big (PB)

characterized by triangular membership functions
 Fig.6 Shows each parameter in membership function of Output.

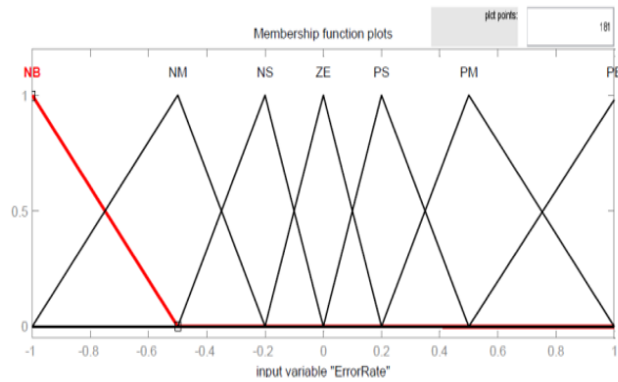

Fig.5 Membership Function of derivative error

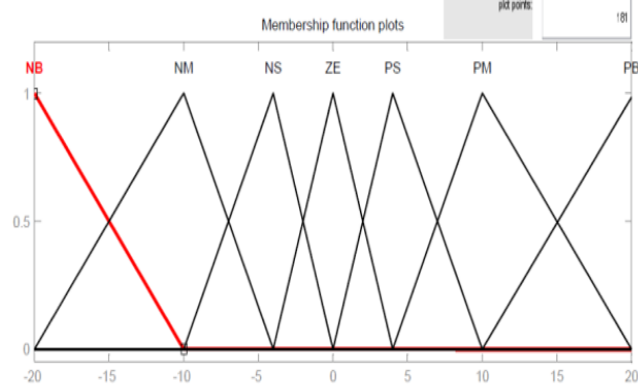

Fig.6 Membership Function of output

Taking into account this the components of the standard table are gotten as appeared in Table 1, with "Vdc" and "Vdc-ref" as inputs.

θ / $\Delta\theta$	NL	NM	NS	Z	PS	PM	PL
NL	NL	NL	NL	NL	NM	NS	Z
NM	NL	NL	NL	NM	NS	Z	PS
NS	NL	NL	NM	NS	Z	PS	PM
Z	NL	NM	NS	Z	PS	PM	PL
PS	NM	NS	Z	PS	PM	PL	PL
PM	NS	Z	PS	PM	PL	PL	PL
PL	NL	NM	NS	Z	PS	PM	PL

Table 1: Fuzzy rules

IV. SIMULATION RESULTS

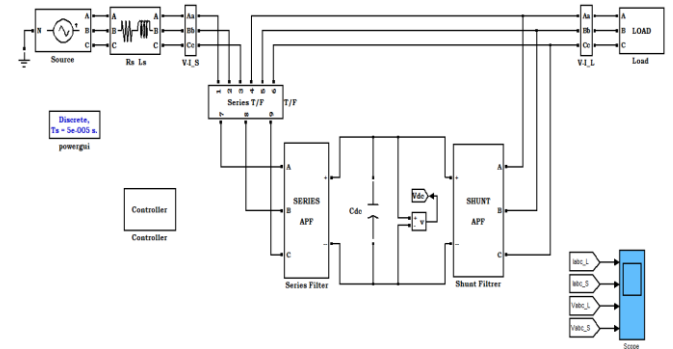

Fig 7simulation circuit of proposed system

Voltage	220V rms value
Grid frequency	60 Hz
Power rate	5 KVA
Dc- link voltage	450 V dc
Dc-link capacitor	C= 9400 μ F
Shunt converter passive filter	R= 3.7 Ω ,L=750 μ H,C= 20 μ F
Series converter passive filter	R= 7.5 Ω , L= 1 mH, C= 20 μ F
Sampling frequency	19440 Hz
Switching frequency	9720 Hz
Pi controller (p _{loss})	K _p = 4.0 ,K _i = 250
Picontroller (q _{statcom})	K _p = 0.5 ,K _i = 50

Table 2: iUPQC parameters

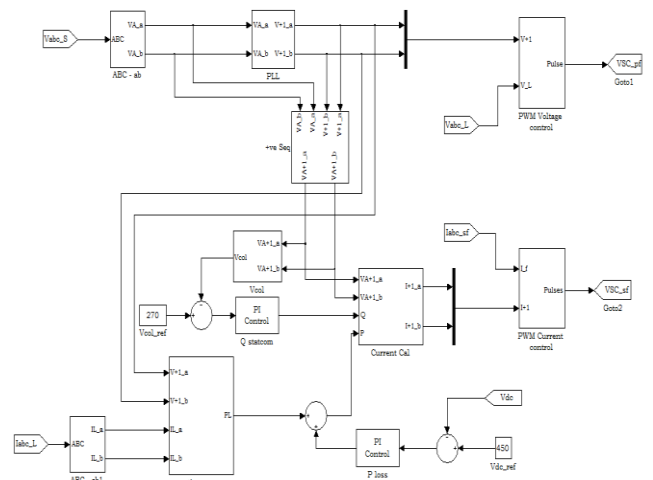

Fig 8 simulation circuit of the novel iUPQC controller

In this paper, in order to verify all the power quality issues, the iUPQC was connected to a grid with a voltage sag system. In this case, the iUPQC behaves as a STATCOM, and the breaker S Sag is closed to cause the voltage sag.

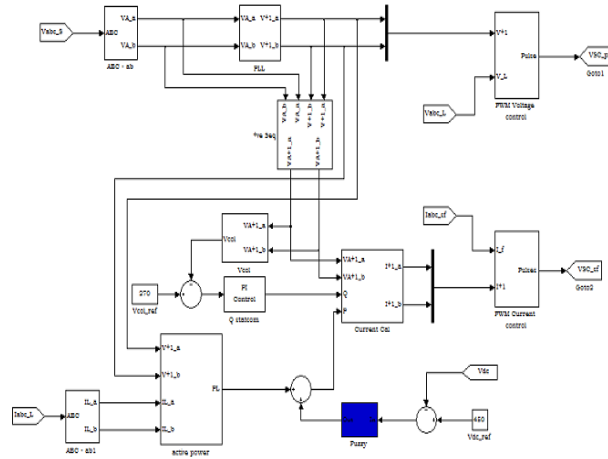

Fig 9 simulation circuit of the Fuzzy controller iupqc

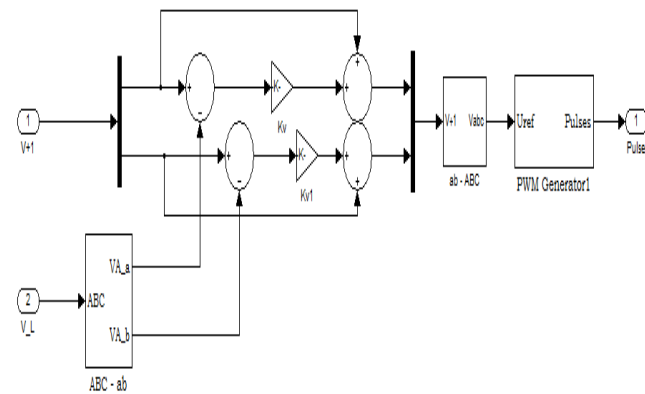

Fig10 simulation circuit of the voltage controller PWM iupqc

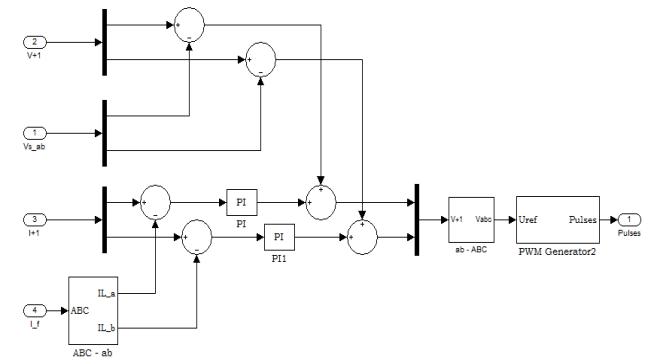

Fig11.simulation circuit of the current controller PWM iupqc

Case 1: To verify the grid-voltage regulation (see Fig. 12), the control of the QSTATCOM variable is enabled to compose (4) at instant $t = 0.04$ s. Before the QSTATCOM variable is enabled, only the dc link and the voltage at bus B are regulated, and there is a voltage sag at bus A, as shown in Fig. 12 After $t = 0.04$ s, the iUPQC starts to draw reactive current from bus A, increasing the voltage until its reference value. As shown in Fig.10, the load voltage at bus B is maintained regulated during all the time, and the grid-voltage regulation of bus A has a fast response.

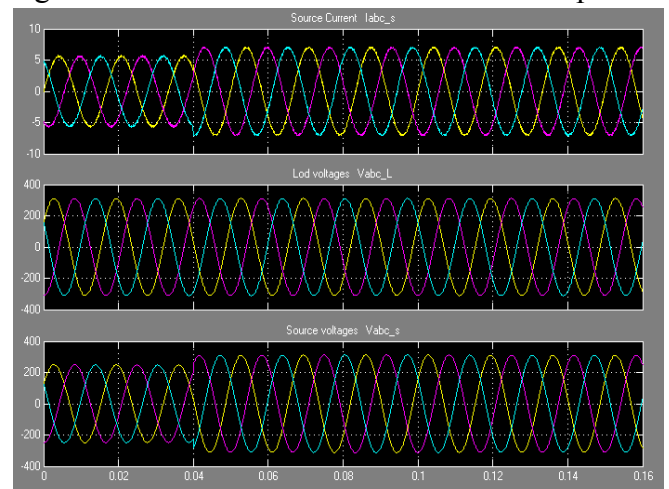

Fig. 12iUPQC response at no load condition: (a) grid voltages VA , (b) load voltages VB , and (c) grid currents

Case 2: Next, the experimental case was carried out to verify the iUPQC performance during the connection of a nonlinear load with the iUPQC already in operation. The load is a three phase diode rectifier with a series RL load at the dc link ($R = 45 \Omega$ and $L = 22$ mH), and the circuit breaker S Sag is permanently closed, with a $LS = 10$ mH. In this way, the voltage-sag disturbance is increased due to the load connection. In Fig.13, it is possible to verify that the iUPQC is able to regulate the voltages simultaneously. Even after the load connection, at $t = 0.04$ s, the voltages are still regulated, and the currents drawn from bus A are almost sinusoidal. Hence, the iUPQC can perform all the power-quality compensations, as

mentioned before, including the grid-voltage regulation. It is important to highlight that the grid-voltage regulation is also achieved by means of the improved iUPQC controller, as introduced in Section III.

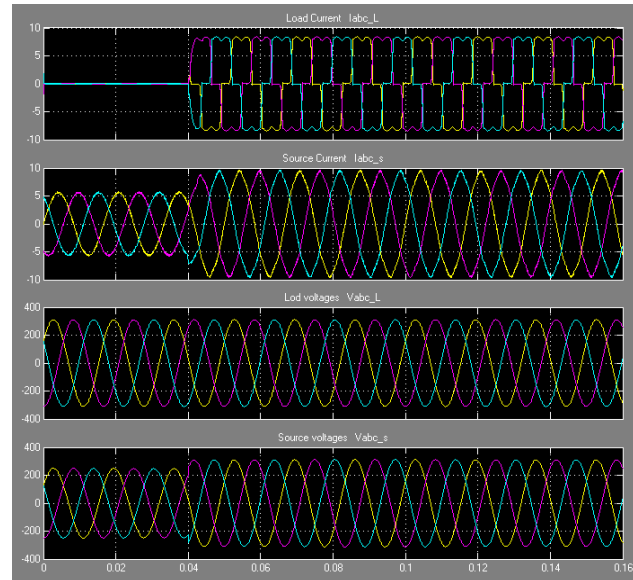

Fig. 13.iUPQC transitory response during the connection of a three phase diode rectifier: (a) load currents, (b) grid currents, (c) load voltages and (d) grid voltages.

Case 3: Finally, the same procedure was performed with the connection of a two-phase diode rectifier, in order to better verify the mitigation of power quality issues. The diode rectifier has the same dc load ($R = 45 \Omega$ and $L = 22 \text{ mH}$) and the same voltage sag ($LS = 10 \text{ mH}$ and $R_{rm \text{ Sag}} = 15 \Omega$). Fig.11 depicts the transitory response of the load connection. Despite the two phase load currents, after the load connection at $t = 0.04 \text{ s}$, the three-phase current drained from the grid has a reduced unbalanced component. Likewise, the unbalance in the voltage at bus A is negligible. Unfortunately, the voltage at bus B has higher unbalance content. These components could be mitigated if the shunt compensator works as an ideal voltage source, i.e., if the filter inductor could be eliminated. In this case, the unbalanced current of the load could be supplied by the shunt converter, and the voltage at the bus B could be exactly the voltage synthesized

by the shunt converter. Therefore, without filter inductor, there would be no unbalance voltage drop in it and the voltage at bus B would remain balanced. However, in a practical case, this inductor cannot be eliminated, and an improved PWM control to compensate voltage unbalances is necessary.

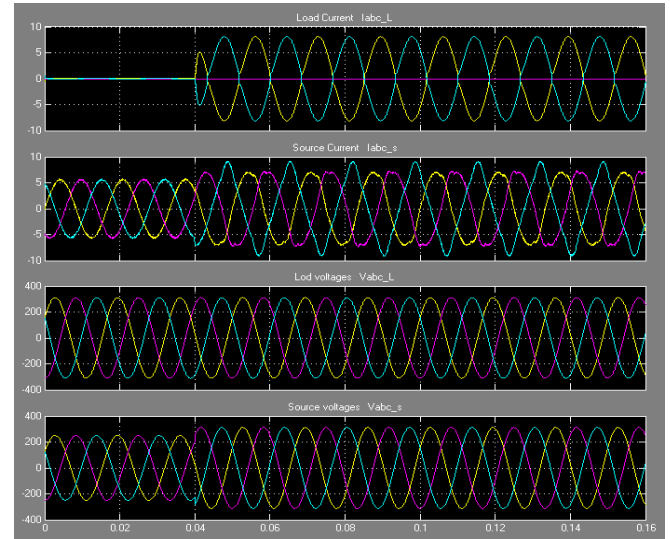

Fig. 14.iUPQC transitory response during the connection of a two phase diode rectifier: (a) load currents, (b) source currents, (c) load voltages, and (d) source voltages

Next, the experimental case was carried out with fuzzy controller in place of PI controller with the same case

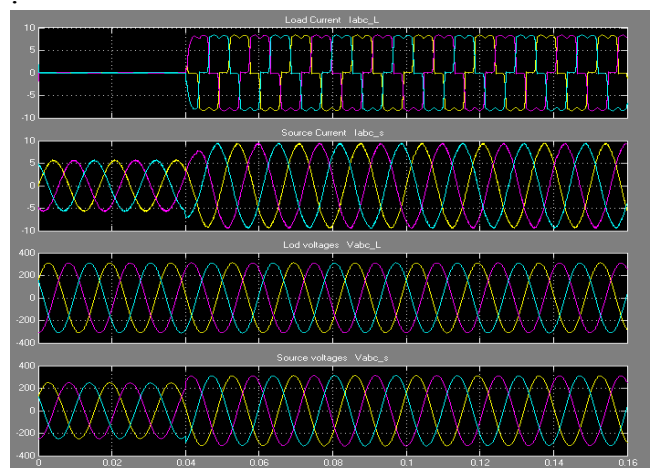

Fig. 15.iUPQC transitory response during the connection of a three phase diode rectifier: (a) load currents, (b) grid currents, (c) load voltages and (d) grid voltages.

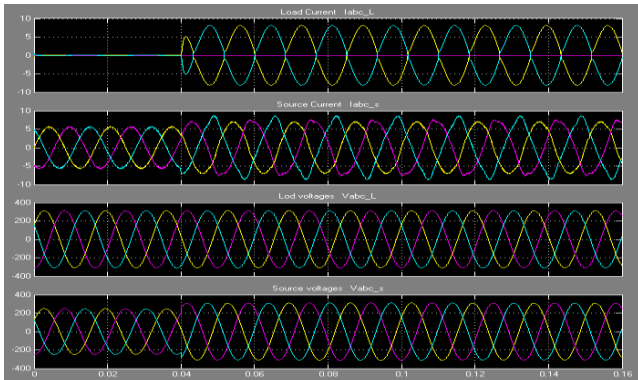

Fig. 16.iUPQC transitory response during the connection of a two-phase diode rectifier: (a) load currents, (b) source currents, (c) load voltages, and (d) source voltages

The %THD value was calculated and shown below which has shown the clear distinguish between PI and Fuzzy logic controller.

Similarly case 1 and 2 was also simulated with fuzzy logic controller and the %THD value has tabulated below

Table 3: THD comparison table

Two Phase Diode Rectifier for Source Current THD			
Controller	A-Phase	B-Phase	C-Phase
PI	6.46%	7.48%	10.21%
FUZZY	4.45%	7.10%	8.70%

Three Phase Diode Rectifier for Source Current THD			
Controller	A-Phase	B-Phase	C-Phase
PI	2.53%	2.54%	2.51%
FUZZY	1.64%	1.65%	1.68%

CONCLUSION:

This paper demonstrates the operation and control of an improved dual topology of unified power quality conditioner (iUPQC). In this improved iUPQC controller, the currents synthesized by the series converter are determined by the average active power of the load and the active power to provide the dc-link voltage regulation, together with an average reactive power to regulate the grid-bus voltage. In this manner all the power-quality compensation features like voltage sag, voltage swell, voltage regulation at load side and grid side achieved. This improved controller also mimics a STATCOM to the grid bus. This new feature enhances the applicability of the iUPQC and provides new solutions in future scenarios involving smart grids and micro grids, including distributed generation and energy storage systems to better deal with the inherent variability of renewable resources such as solar and wind power. Moreover, the improved iUPQC controller may justify the costs and its promotes the iUPQC applicability in power quality issues of critical systems. Despite the addition of one more power-quality compensation feature, the grid-voltage regulation reduces the inner-loop circulating power inside the iUPQC, which would allow lower power rating for the series converter.

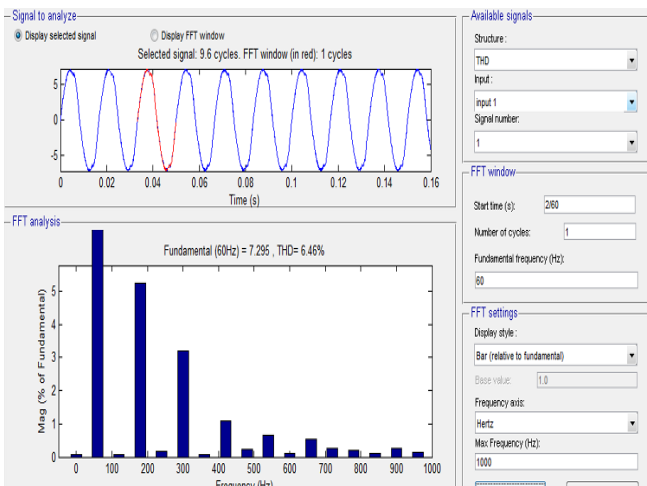

Fig 17 % THD using PI controller

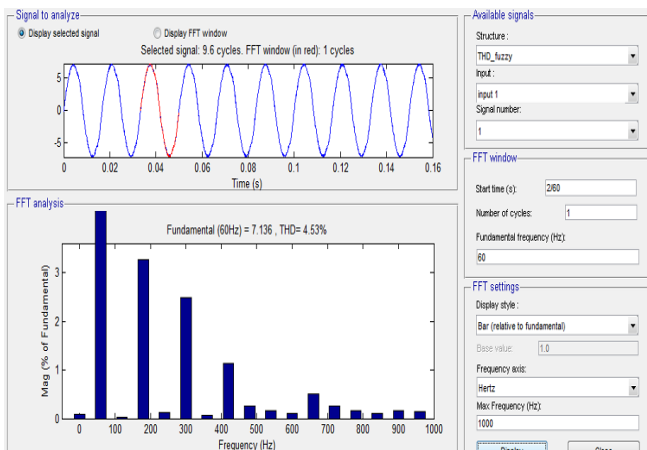

Fig 18 % THD using Fuzzy logic controller

Simulation results and comparison table of % THD verified a suitable performance of voltage regulation at both sides of the iUPQC, and Fuzzy logic controller is better than PI in compensating harmonic currents and voltage imbalances.

REFERENCES

- [1] Bruno W. França, Student Member, IEEE, Leonardo F. da Silva, "An Improved iUPQC Controller to Provide Additional Grid-Voltage Regulation as a STATCOM" *IEEE transactions on industrial electronics*, vol. 62, no. 3, March 2015
- [2] K. Karanki, G. Geddada, M. K. Mishra, and B. K. Kumar, "A modified three-phase four-wire UPQC topology with reduced DC-link voltage rating," *IEEE Trans. Ind. Electron.*, vol. 60, no. 9, pp. 3555–3566, Sep. 2013.
- [3] V. Khadkikar and A. Chandra, "A new control philosophy for a unified power quality conditioner (UPQC) to coordinate load-reactive power demand between shunt and series inverters," *IEEE Trans. Power Del.*, vol. 23, no. 4, pp. 2522–2534, Oct. 2008.
- [4] K. H. Kwan, P. L. So, and Y. C. Chu, "An output regulation-based unified power quality conditioner with Kalman filters," *IEEE Trans. Ind. Electron.*, vol. 59, no. 11, pp. 4248–4262, Nov. 2012.
- [5] A. Mokhtatpour and H. A. Shayanfar, "Power quality compensation as well as power flow control using of unified power quality conditioner," in *Proc. APPEEC*, 2011, pp. 1–4.
- [6] J. A. Munoz et al., "Design of a discrete-time linear control strategy for a multicell UPQC," *IEEE Trans. Ind. Electron.*, vol. 59, no. 10, pp. 3797–3807, Oct. 2012.
- [7] V. Khadkikar and A. Chandra, "UPQC-S: A novel concept of simultaneous voltage sag/swell and load reactive power compensations utilizing series inverter of UPQC," *IEEE Trans. Power Electron.*, vol. 26, no. 9, pp. 2414–2425, Sep. 2011.
- [8] V. Khadkikar, "Enhancing electric power quality using UPQC: A comprehensive overview," *IEEE Trans. Power Electron.*, vol. 27, no. 5, pp. 2284–2297, May 2012.
- [9] L. G. B. Rolim, "Custom power interfaces for renewable energy sources," in *Proc. IEEE ISIE*, 2007, pp. 2673–2678.
- [10] N. Voraphonpipit and S. Chatratana, "STATCOM analysis and controller design for power system voltage regulation," in *Proc. IEEE/PES Transmiss. Distrib. Conf. Exhib.—Asia Pac.*, 2005, pp. 1–6.
- [11] J. J. Sanchez-Gasca, N. W. Miller, E. V. Larsen, A. Edris, and D. A. Bradshaw, "Potential benefits of STATCOM application to improve generation station performance," in *Proc. IEEE/PES Transmiss. Distrib. Conf. Expo.*, 2001, vol. 2, pp. 1123–1128.
- [12] A. P. Jayam, N. K. Ardeshta, and B. H. Chowdhury, "Application of STATCOM for improved reliability of power grid containing a wind turbine," in *Proc. IEEE Power Energy Soc. Gen. Meet.—Convers. Del. Elect. Energy 21st Century*, 2008, pp. 1–7.
- [13] C. A. Sepulveda, J. A. Munoz, J. R. Espinoza, M. E. Figueroa, and P. E. Melin, "All-on-chip dq-frame based D-STATCOM control implementation in a low-cost FPGA," *IEEE Trans. Ind. Electron.*, vol. 60, no. 2, pp. 659–669, Feb. 2013.
- [14] B. Singh and S. R. Arya, "Back-propagation control algorithm for power quality improvement using DSTATCOM," *IEEE Trans. Ind. Electron.*, vol. 61, no. 3, pp. 1204–1212, Mar. 2014.
- [15] M. Aredes and R. M. Fernandes, "A dual topology of unified power quality conditioner: The iUPQC," in *Proc. EPE Conf. Appl.*, 2009, pp. 1–10.
- [16] M. Aredes and R. M. Fernandes, "A unified power quality conditioner with voltage sag/swell compensation capability," in *Proc. COBEP*, 2009, pp. 218–224.
- [17] B. W. Franca and M. Aredes, "Comparisons between the UPQC and its dual topology (iUPQC) in dynamic response and steady-state," in *Proc. 37th IEEE IECON*, 2011, pp. 1232–1237.
- [18] B. W. Franca, L. G. B. Rolim, and M. Aredes, "Frequency switching analysis of an iUPQC with hardware-in-the-loop development tool," in *Proc. 14th EPE Conf. Appl.*, 2011, pp. 1–6.
- [19] B. W. Franca, L. F. da Silva, and M. Aredes, "Comparison between alpha and DQ-PI controller applied to IUPQC operation," in *Proc. COBEP*, 2011, pp. 306–311.
- [20] R. J. Millnitz dos Santos, M. Mezaroba, and J. C. da Cunha, "A dual unified power quality conditioner using a simplified control technique," in *Proc. COBEP*, 2011, pp. 486–49.