

CONTROL AND ANALYSIS OF POWER QUALITY ISSUES ON DOUBLE FED INDUCTION GENERATOR BASED WIND ENERGY SYSTEM

G. RAJANI

Assistant Professor, MRECW,
Maisammaguda, Secunderabad, Telangana
Email id: rajani.gulagattu@gmail.com

N. RAMESH

Assistant Professor, MRCET,
Email id: rameshnadipena@gmail.com

ABSTRACT:

With developing worries about environmental pollution and a conceivable vitality lack, extraordinary endeavours have been taken by the administrations around the globe to actualize sustainable power source programs, construct chiefly in light of wind control, sun energy, little hydro-electric power, and so on. Because of its many focal points, for example, the enhanced power quality, high energy proficiency and controllability, and so forth., the variable speed wind turbine utilizing a double fed induction generator (DFIG) is turning into a well known idea and in this way the demonstrating of the DFIG based wind turbine turns into an intriguing examination theme. In this paper the enduring state examination and control of double fed induction generator (DFIG) for variable speed wind energy transformation framework is contemplated. The goal is to break down the execution of DFIG under unflinching state conditions. Stator arranged voltage control is utilized to accomplish the free control of dynamic and responsive energy of the machine. The total re-enactment show is created for such machine under factor speed operation utilizing MATLAB/SIMULINK condition for adequacy of the study. Traditionally, control of DFIG is accomplished by voltage Oriented Control (VOC), this strategy decouples the rotor streams into dynamic and responsive parts; control of the dynamic and receptive forces is accomplished in a roundabout way by controlling the info ebbs and flows. However this controller depends profoundly on parameter varieties of the DFIG. Direct Power Control (DPC), without internal current control circles, delivers a quick and vigorous power reaction. Re-enactment comes about on a 1.5 MW DFIG system are given to exhibit the control procedure and the expansive enthusiasm of vitality stockpiling in such breeze vitality transformation frameworks (WECS).

Keywords: Double fed Induction Generator (DFIG), Wind Turbine, Vector Control, d-q theory, synchronous rotating, reference frame, direct power control, storage unit.

INTRODUCTION

Wind is renewable and non-conventional energy source, which is the result of uneven heating up of the earth surface by the sun. Wind energy is one of the most important and promising sources of renewable energy all over the world, because it is non-polluting and economically viable [1]-[3]. Nowadays environmental pollution more and energy shortage than around the all over world has taken scheme to implement renewable source more and more for examples small hydroelectric power, wind power, solar energy etc. main significant to development renewable energy improving techniques, reducing costs and low environmental impact[8]. With increasing on wind energy having many applications over wide range few kilowatts to several megawatts in small scales off grid farms. This kind of power generation causes problems in the electrical system because of the lack or security of control on the produced active and reactive power [9]. The fixed speed wind turbine is relatively simple and robust it is not preferred as it has a number of disadvantages [6]. Due to this most of the wind turbine manufactures are increasingly shifting towards variable speed concepts because

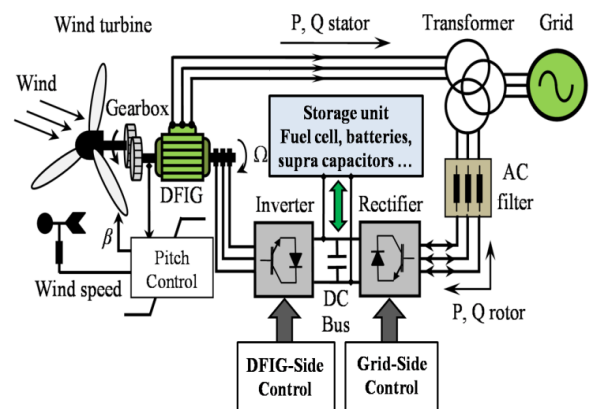

Fig .1 WECS based a DFIG configuration including a storage unit

of its easy and simple pitch control, mechanical load reduction and high energy yield when compared to constant speed wind turbines, less fluctuations in output and extensive controllability of both active and reactive power contribute to their selection of variable speed concepts [7].on variable speed wind turbine is investigated as a viable alternative to adjust speed a wide range while keeping cost of the power converters minimal [10].

I. CONTROL SCHEME

A. Voltage Control Strategy

In WECS, the machine attracts receptive power at first to begin with. Consequently VAR remuneration is a noteworthy issue in WECS. Capacitor banks, if included parallel to machine may prompt over-voltages. On the off chance that an extra gadget, for example, STATCOM/SVC and so forth, are added may prompt multifaceted nature in charge and may cause uneconomic costs. In this framework, DFIG with consecutive converter, the matrix side converter itself goes about as a remunerating gadget and keeps up UPF at lattice side. Different control strategies are accounted for of which voltage arranged control and reference current age control is straightforward and straightforwardness to actualize. For the doubly sustained enlistment machine in transient state wanted measure of receptive power stream into the stator which can controlled by controlling i_{dr} and stator dynamic power can be controlled P_s by means of i_{dr} . Thus no need have decoupled to execute of field introduction control for slip control recuperation framework Figure (2) demonstrates the control methodology of DFIG. This can control from both stator side and also rotor side of receptive and dynamic power with slip control differs. A current managed beat with regulation voltage source inverter gives field situated streams i_{dr} and i_{qr} to rotor circuit controlling dynamic and receptive power, separately. The turbine ideal torque speed profile given by dynamic power charge same as limit the machine copper misfortunes summon given by receptive influence and by implication torque will be control as given condition. D-q reference outline used to decide by the machine stator motion and streams additionally field situated, dynamic and receptive power lattice (P_{grid} and Q_{grid}) likewise controlled. To balance out the dc transport voltage with P_{grid} is controlled through I_{qr} and to meet the general responsive power charge mind Q_{grid} is controlled through i_{dr} .

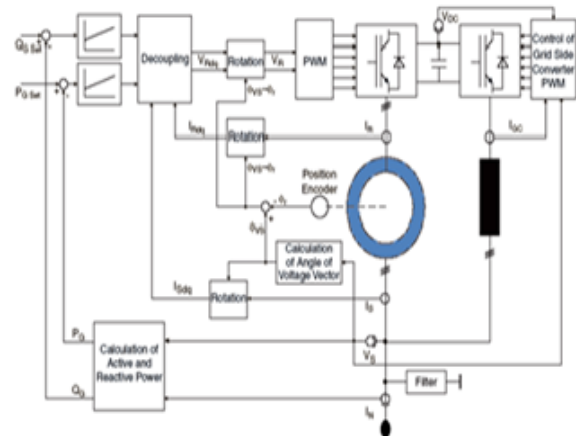

Fig.2: Voltage control strategy of DFIG

B. Direct power control strategy

The DPC depends on similar control standards as the DTC procedure, the novel contrast is the specifically controlled factors. On account of the DTC, the electromagnetic torque and the rotor transition are straightforwardly controlled while in the DPC, the stator dynamic and responsive forces are controlled. Initial a theoretical investigation of the customary DPC procedure will be completed. For this situation, we exhibit the DPC by utilizing tow levels voltage source inverter (2L-VSI) which supplies the rotor windings as we appeared in Fig. 4.

II. SIMULATION RESULTS

A. For Voltage Oriented Control Scheme:

The main objective of the grid side converter is to maintain dc-link voltage constant for necessary action. The voltage oriented control technique is approached to solve this issue. The PWM converter is current regulated with the direct axis current is being used to regulate the DC link voltage where as the quadrature axis current component is used to regulate the reactive power.

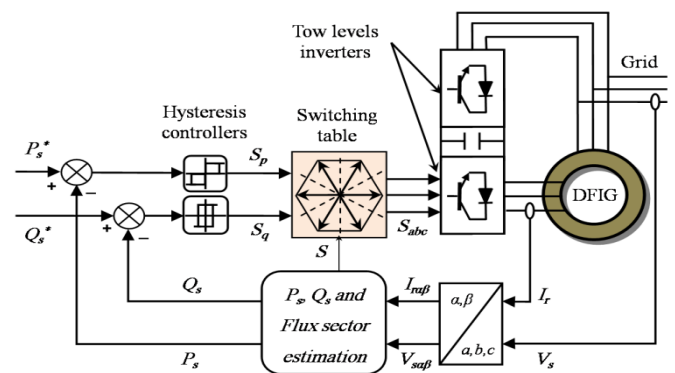

Fig. 4: Schematic diagram of DPC strategy for DFIG

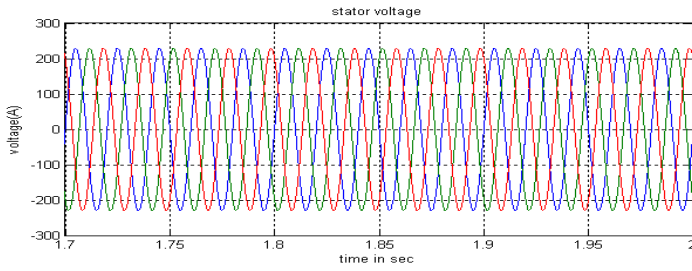

Fig.5: Stator Voltage Waveform

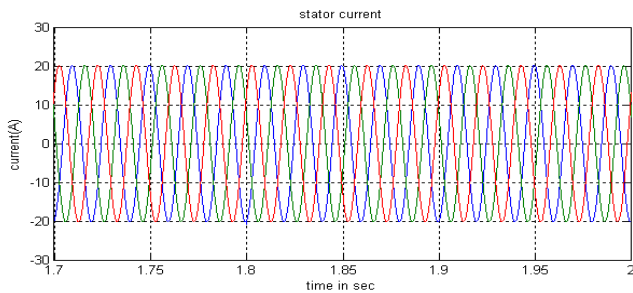

Fig.6: stator current waveform

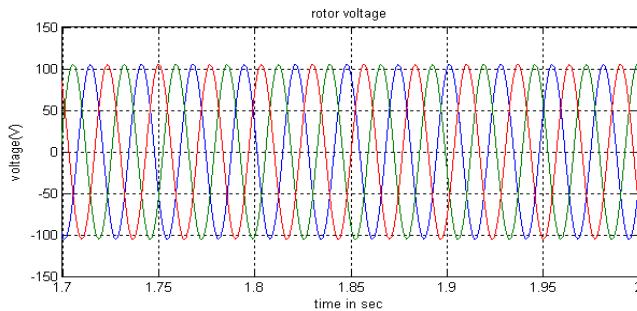

Fig.7: Rotor Voltage Wave form

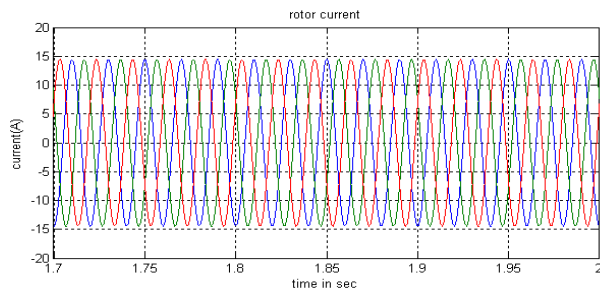

Fig.8: Rotor Current Waveform

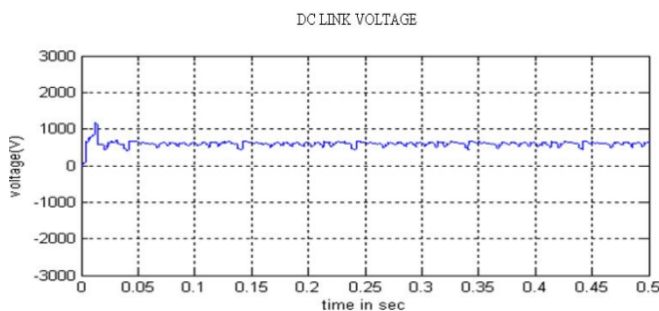

Fig. 9: DC Link Voltage Output Waveform

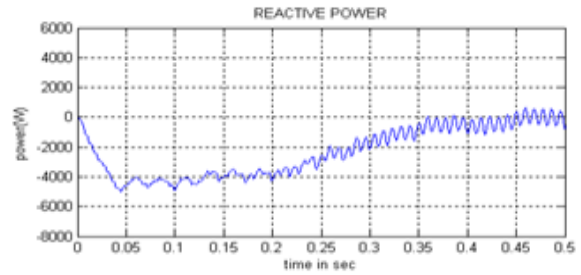

Fig.10: Reactive Power Output Waveform Form

B. For Direct Power Control Scheme:

Simulation results for a 1.5 MW DFIG associated with a 0.75 MW storage unit. The wind turbine is also supposed to inject a constant power of 0.75 MW into the grid for all wind conditions. The direct power control strategy is simulated at 100 μ s sampling period. Simulation results for DPC are presented in Fig. 11.

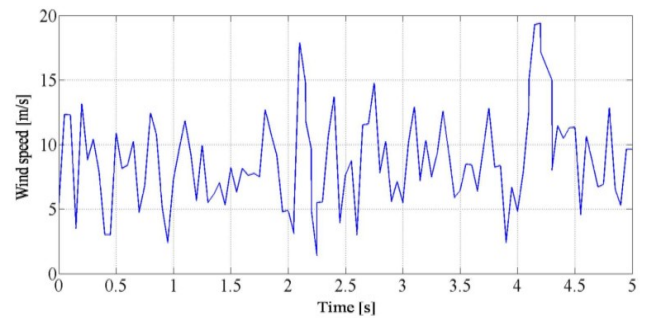

Fig.11(a)

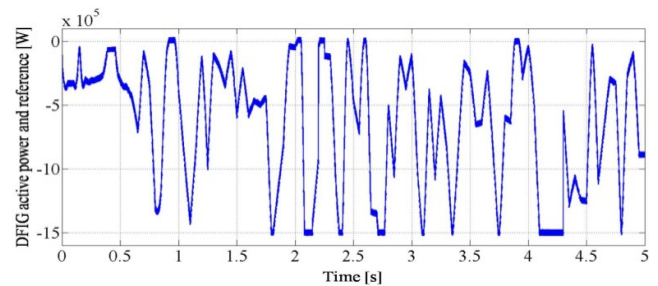

Fig.11(b)

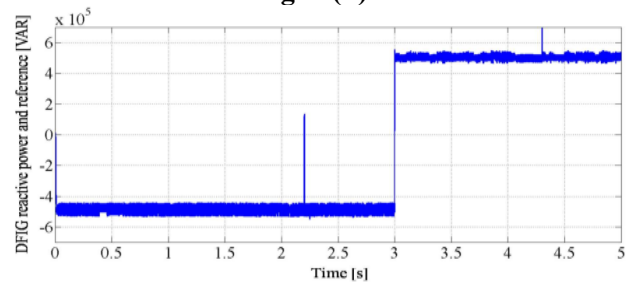

Fig. 11(c)

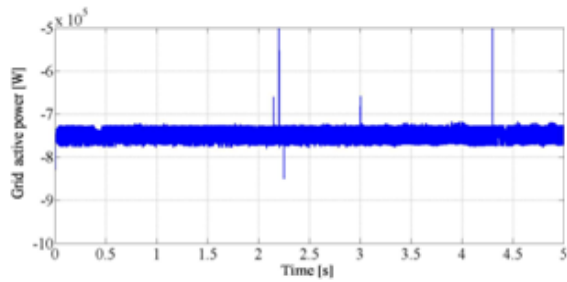

Fig. 11(d)

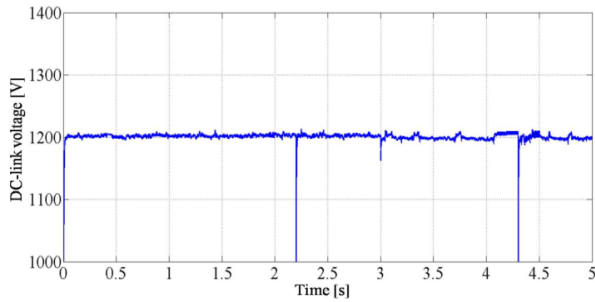

Fig. 11(e)

Fig. 11: DPC Strategy Responses

TABULATION FOR VARIOUS SPEEDS

SPEED (RPM)	STATOR POWER (W)	ROTOR POWER (W)	DC LINK VOLTAGE (V)
1145.9	-987	83	600
1336.9	-1385	240	600
1623.3	-2983	-252	600
1718.8	-3550	-510	600

III. CONCLUSION

The DFIG is these days a well known decision for wind vitality transformation frameworks. This ubiquity is mostly due to its capacity for vast variable speed drive. Detailed models of the DFIG have been investigated with required parameters and their creating method of operation is clarified unmistakably with help of waveforms acquired from re-enactment comes about. In this paper the power issues and their investigation has been presented the procedures have been utilized for reference tracking and decoupling of dynamic and reactive powers traded between the stator of the DFIG and the network by controlling the rotor converter. DFIG is regularly utilized as a part of

wind energy transformation system, that's the reason the model of the DFIG has been associated with a wind turbine display. The capacity to provide constant dynamic power infused to the lattice, which is both deterministic and impervious to wind speed fluctuations. Reproduction comes about show the effectiveness of the DPC technique to control active and receptive power autonomously with good performances. Then again, they demonstrate the large enthusiasm of energy stockpiling in such wind energy conversion systems.

REFERENCES

[1] S. Muller, M. Deicke and R.W. DeDoncker, "Doubly fed induction generator systems for wind turbine", *IEEE Industry Applications Magazine*, Vol.8, No. 3, 2002, pp. 26-33.

[2] A.Tapia, G.Ostolaza and J.X. Saenz, "Modelling and control of a wind turbine driven doubly fed induction generator", *IEEE Transactions on Energy Conversion*, Vol. 18, June 2003, pp. 194- 204.

[3] Lucian Mihet-Popa, Frede Blaabrierg, "Wind Turbine Generator Modelling and Simulation Where Rotational Speed is the Controlled Variable", *IEEE Transactions on Industry Applications*, Vol.40, No.1, January/February 2004.

[4] Andrew Miller, Edward Mulijadi, Donald S. Zinger, "A Variable Speed Wind Turbine Power Control", *IEEE Transactions on Energy Conversion*, vol.12, no.2, June 1997.

[5] ShuhuiLi, A, "Simulation Analysis of Double-Fed Induction Generator for Wind Energy Conversion Using P Spice", *IEEE Power Engineering Society General Meeting*, 18-22 June 2006.

[6] S.J. Chapman, *Electric Machinery Fundamentals*, New York: The McGraw-Hill Companies, 1999.

[7] R. Pena, J. C. Clare and G. M. Asher, "Doubly fed induction generator using back-to-back PWM converts and its application to variable speed wind-energy generation", *IEE Proceedings Electrical Power Application*, Vol. 143, No.3, pp. 231-241, May 1996.

[8] B. Chitti Babu, K.B. Mohanty and C. Poongothai, "Performance of Double-Output Induction Generator for Wind Energy Conversion Systems", *Proceeding of IEEE*, 2008, pp.933-938.

[9] J.G. Sloopweg, H. Polinder and W.L. Kling,

"Dynamic Modelling of a Wind Turbine with Doubly Fed Induction Generator", Proceedings of IEEE 2001.

[10] B.H.Chowary, Srinivas Chellapilla, "Doubly-fed induction generator for variable speed wind power generation" *Transactions on Electric Power System Research*, Vol.76,pp. 786-800, Jan 2006.

[11] Yazhou Lei, Alan Mullane, Gordon Lightbody, and Robert Yacamini, "Modelling of the Wind Turbine with a Doubly Fed Induction Generator for Grid Integration Studies" *IEEE transactions on energy conversion*, vol. 21, no. 1, march 2006.

[12] ManasiPattnaik, "Study Of Doubly Fed Induction Generator for Variable Speed Wind Energy Conversion Systems", *Special Issue of International Journal Of Power System Operation and Energy Management*, ISSN (PRINT):2231-4407, Vol - 1, Issue - 3.

[13] F. Poitiers, M. Machmoum, R. Le Doeuff and M.E. Zaim, "Control Of A Doubly-Fed Induction Generator for Wind Energy Conversion System", *GE44-LARGE*, Ecolepoly technique de l'universite`de Nantes, Saint Nazaire, France.