



A MULTITASKING MANIPULATE ALGORITHM FOR GRID LINK UP INVERTER IN CIRCULATED PROPAGATION DILIGENCES

K. MALATI MOURYA

M. Tech (power electronics),
Malla Reddy Institute of Engineering and
Technology

U. LILI KUMAR

M. Tech, Assistant professor-Dept of
Electrical and Electronics Engineering
Malla Reddy Institute of Engineering and
Technology

ABSTRACT

This project proposes a multitasking manage algorithm for grid-linked inverters (GCI) in distributed new release (DG) purposes. A single-phase H-bridge voltage supply inverter is exploited as a vigor digital interface between the DG procedure and the grid. The proposed manipulate algorithm produce the GCI in mongrel-appoint function manner to attain aspiration lively energy injection to the grid. Additionally to lively energy injection, the proposed manipulate algorithm has current harmonics mitigation and reactive vigor compensation capabilities for energy exceptional enhancement. The manipulate algorithm makes use of simplest the rest capacity of the GCI for best growth of energy. The proposed manage algorithm employs a current decomposition constitution headquartered on more than one adaptive interference offset filters for pulling of sympathetic and acute currents of the topical anesthetic hundreds. The pull out sympathetic are utilized in computing overcompensate currents to be shorted through the GCI.

Key Terms: Grid linked inverters, Distribution generation, Harmonics,

1.INTRODUCTION

Now away days the distributed generation (DG) systems based on renewable energy sources (RESs) are playing important role in world's energy supply system due to their low carbon emission, cost effectiveness and high efficiency. Small scale RES such as

roof-top solar and wind power generation systems and fuel cells are usually connected to the single-phase utility grid through power electronic interfaces. The grid is facing severe power quality issues due to the extensive use of nonlinear and reactive loads such as switching mode power supplies, light controllers, arc furnaces, ac voltage regulators and variable speed drives. The harmonic and reactive currents drawn by these polluting loads are causing poor line power factor and voltage distortion leading to reduced utilization and increased losses of the distribution system. To suppress the current harmonics injected by residential and commercial loads, power line conditioners such as shunt active power filters (APFs) are being extensively employed. The power electronic interfaces used in the DG systems such as voltage source inverters (VSI) can further degrade the grid power quality if not properly designed and controlled.

For active harmonic filtering and reactive power compensation, precise estimation of load harmonics and reactive current is necessary. Several methodologies for harmonic current extraction have been reported in the literature. The harmonic components of a distorted current signal can be characterized by their amplitude,



frequency and phase-angle. Various techniques to calculate these quantities have been compared. The harmonics estimation techniques can be widely classified as time-domain and frequency-domain methods. In time domain, synchronous rotating $d - q$ frame theory, instantaneous $p - q$ theory and generalized integrators-based approaches are the widely used methods for extraction of harmonic content. According to the time domain methods offer increased speed and reduced calculations compared to the frequency domain methods. Inherently, the instantaneous $p - q$ method and synchronous rotating $d - q$ frame method are applicable to three-phase systems. Application of these methods for single-phase systems can be found in the literature. For accurate estimation of harmonic currents using instantaneous $p - q$ theory, clean voltage signals are required. Therefore, fundamental component of voltage must be used to extract the harmonic content in load currents under distorted grid conditions. In instantaneous $p - q$ theory, it is possible to separate harmonics and fundamental component, but harmonics decomposition cannot be carried out. In synchronous rotating $d - q$ frame method, it is possible to extract individual harmonics with the help of multiple $d - q$ frames rotating at harmonic frequencies. In synchronous rotating $d - q$ frame method, the accuracy and speed of the extraction process highly depends on phase-angle provided by the phase locked loop (PLL). Obtaining certain attributes of harmonic signals such as amplitude, phase-angle and frequency using multiple second order generalized integrators (MSOGI) has been discussed. Though the MSOGI

technique can successfully estimate the individual harmonics, the reactive component of fundamental current and its RMS value have to be estimated separately for reactive power compensation as illustrated. Frequency domain methods include discrete Fourier transforms and its variants such as fast Fourier transforms (FFT), short time Fourier transform and recursive discrete Fourier transforms.

Due to their adaptive tracking ability, accuracy and robustness, NN-based control schemes have gained much attention in active harmonic filtering. In [19], NN-based notch filter is employed to estimate compensating current from the sensed load current. A control scheme based on novel adaptive linear neuron (ADALINE) technique was proposed in [20] to mitigate the power quality problems. Multiple ADALINE structures have been used to improve the transient response of the control system. Mukhtiar *et al.* have developed neuro-fuzzy controller for power quality improvement using grid interfaced RES based DG inverter. In another NN technique based on recursive least squares is reported for fundamental component extraction. It has also used multiple structures to increase the adaptation speed. Despite their adaptive ness and better tracking ability, NN-based control strategies require prior information about the system and signal and they cannot be implemented using analog devices requires digital processors.

II.LITERATURE SURVEY

Types of Renewable Energy Sources

1. Water prestige
2. Solar sovereignty



3. Wind strength
4. Geo roasting law

Water management:

The law of wet is generous. Water prestige accounts for 73 bonus of all inexhaustible strength in keeping with the Energy Information Administration (EIA). Water law is caused practicing the mechanical dynamism of streaming wet by forcing it straight pipes, whatever then turns a dynamo on the part of cultivating DC. Water strength also consists of streaming and wave strength, both in the toddler organize of the probe, as scientists try to observe how to tackle strength cultivated respectively ocean's trend.

Solar management:

Solar cells describe silicon take in the sun's radioactivity, also known as solar collector. The photovoltaic alter involves the development and rearrangement of voltage to take in the sun's distribution and forge heat, but efficient are also heliacal processes that use considerable mirrors to heat thin, or present tropical heat and provoke puissance, whatever is acclimated turn a alternator.

Wind management:

Wind strength is a very honest movement. A wind generator converts the faction strength of wind into mechanical electricity specifically at home with make DC. The strength is fed straight a alternator, reformed then into mechanical potential, and then transmitted to a management station. Wind prestige is rich in some states, with the greatest wind farms placed in Texas. Wind is exceptional in as much as it carries

incentives for farmers to give parcels of land for home wind generators, and has divine probable up to unlimited endorsement for the sake of the huge areas of land with logical wind handy to utilize.

Geo thermic sovereignty:

The alter involves trapping heat covered, and then house electricity that rises near the façade in the form of heat. When this heat normally forges hot wet or potency, it is exploited and then acclimated turn a might generator to make DC. Geo melting potential gain used for profitable purposes in the promptly 1900s.

III.HARMONICS

The quintessential explanation for a musical is “a sinusoidal unit of a recurring wave or volume having regularity specifically an indispensable multiplex of the intrinsic recurrence. Some references see “good” or “pure” prestige as the above-mentioned left out any consonants. But such perfect waveforms commonplace only endures in a research laboratory. Harmonics have aged for a skilled and will end do so. In fact, pieces have been attuned such ago the forgery of the varsity or woodwind vehicle. Harmonics (termed “overtones” in singing) generators try to present DC strength locus the electricity waveform has lone density correspond it, the principal regularity. In the North America, this recurrence is 60 Hz or cycles per assist. In European countries and new parts of the everyone, this recurrence is frequently 50 Hz. Aircraft generally use 400 Hz as the law regularity. At 60 Hz, this step that sixty times a approve, the electricity waveform increases to a top practical

quality, then decreases to zero, then decreasing to a peak adverse importance, and then back to zero. The rate at and that the above-mentioned turns reveal are the trigonometric role named a Lissajous figure, as demonstrated in fathom 1. This situation crop ups in many easy experiences, in the manner, that the further of a pressure as it swings up and down, or the way a line on a violin vibrates when plucked.

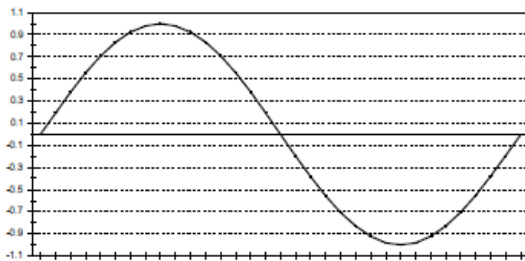

Figure.1 Sine wave

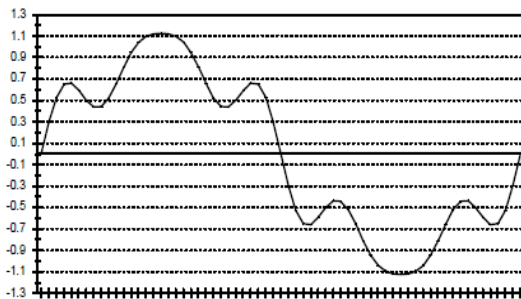

Figure.2 Fundamental with two harmonics

In tell planned able to resolve complicated alarms that have many original frequencies current, a few of analytical methods perform. One of the more familiar is termed the Fourier Transform. However, duplicating the geometrical steps recommended in a silicon chip or computer-based organ is somewhat demanding. So more appropriate treats, christened the FFT for Fast Fourier remodel, or DFT for Discrete Fourier Transform is used.

IV. PROPOSED CONCEPT

A) SYSTEM CONFIGURATION

The schematic of the electrical system is shown in Fig. The system having a single-phase grid, a H-bridge VSI, and local loads. The grid is feeding both linear and nonlinear loads. The VSI is connected to the single-phase grid and in parallel to the local loads at the PCC through an interfacing inductor. The VSI is supplied with a constant voltage dc source which is formed by RESs. Various signals and parameters in the systems are indicated in Fig.5.1. The single-phase grid voltage behind the grid impedance is represented as v_g . The grid impedance consists of inductance L_g and resistance R_g . The interfacing inductance is represented as L_f and its parasitic resistance is denoted as R_f . The signals of PCC voltage, dc bus voltage, grid current, GCI current and load current are denoted as v_{pcc} , V_{dc} , i_g , i_{vsi} and i_l , respectively.

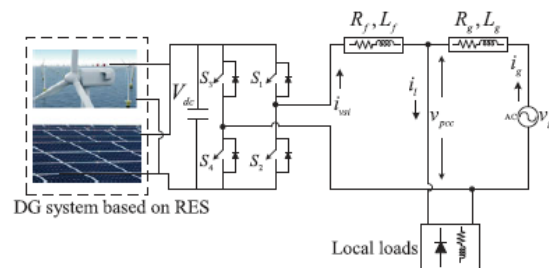

Fig.3 Schematic of single-phase GCI system.

B) CONTROL ALGORITHM

This section presents the proposed multiple ANC filters-based control algorithm for single-phase GCI for reference power injection and power quality based ancillary services. The control algorithm is formulated to operate the GCI as controlled current source. The control scheme would require sensing of signals v_{pcc} , i_{vsi} and i_l and use them as feedback signals. The

sensed load current is processed through multiple ANC filters-based structure.

ANC Filter

The ANC filter diagram is shown in Fig.5.2. The ANC filter has two inputs, namely phase angle (θ) and il . To obtain the θ of fundamental PCC voltage (v_{pccf}), a single-phase PLL is used and the output of PLL is applied to the ANC filter as shown in Fig.5.2. Since the phase-angle of v_{pccf} is used instead of v_{pcc} 's, it makes the proposed control algorithm and harmonics extraction process adaptive to the frequency fluctuations and PCC voltage distortions. The working principle of the ANC filter can be understood as follows: If the error signal “ e ” has the same frequency component as $\cos \theta$, the output of multiplier M_p contains a dc component along with some ac components as illustrated in below equation.

$$M_p = e \times \cos \theta = \overline{M_p} + \widetilde{M_p}$$

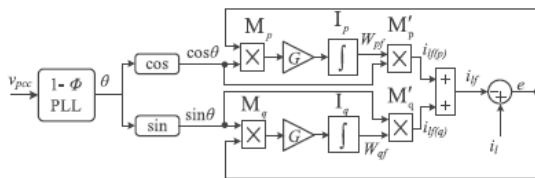

Fig.4 ANC filter.

where “ e ” is the difference between actual load current (il) and its fundamental component (ilf).

The ac components are then filtered by integrator and the dc component is summed up to produce a gradually increasing or decreasing weight W_{pf} .

$$W_{pf} = G \int (\overline{M_p} + \widetilde{M_p}) dt$$

where G is the gain parameter. It highly affects the detection performance. The

smaller the value of G , the higher the detection precision and the longer the dynamic response time of ANC filter and vice-versa. Therefore, a tradeoff value of G should be chosen suitably.

Multiple ANC Filters-Based Structure

In case of single ANC-filter, the integrators have to filter certain lower order harmonics like third, fifth, seventh and so on, that are very close to the fundamental. For lower order harmonics, more selective filtering is required which in turn demands reduced G value. Small value of G results in slow filter response leading to reduced of adaptation speed. Therefore, the only way to increase the adaptation speed is by making the error signal “ e ” free from lower order harmonics without decreasing the G value. This can be achieved by using multiple ANC-filters based harmonics decomposition structure as shown in Fig.

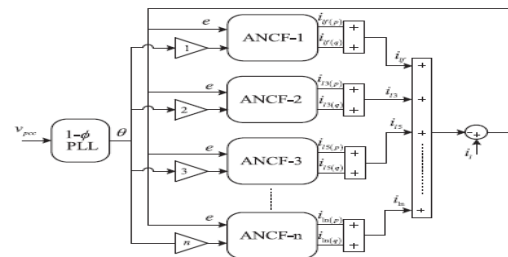

Fig.5 Block diagram of multiple ANC filters-based fundamental extraction.

As it can be seen, a set of n ANC filters tuned at various harmonic frequencies are working in parallel. The block ANCF-1 is used to estimate the fundamental frequency component. Similarly, the block ANCF- n gives information about n th harmonic component of load current. In the present study, up to 21st harmonics have been considered. The error signal is redefined as

$$e(k) = i_l(k) - \sum_{h=1,2,3..n} i_{lh}(k)$$

where i_{lh} is the h th component of i_l . In addition to fundamental component, the multiple ANC-filters structure also outputs harmonic components of the load current. The RMS values of the extracted load harmonics are estimated as

$$I_{lh} = \frac{\sqrt{W_{ph}^2 + W_{qh}^2}}{\sqrt{2}} \quad h=2,3..n$$

The error signal “ e ” in (13) is free from several harmonic components, where as in Fig. the error signal carries all the dominant harmonics. Since the signal “ e ” is free from most of the dominant harmonics, large value of G can be used to improve the transient response of the filtering structure. The performances of single and multiple ANC filter(s)-based structures are illustrated in Fig.5.4 for comparison. Same value for G is considered in both the methods. The waveforms of e , i_l and $i_{lf}(p)$ are presented in Fig.to evaluate the performances.

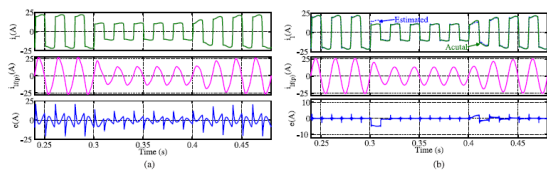

Fig.5.1 Extraction of fundamental active power component of load current using (a) Single ANC filter. (b) Multiple ANC filters.

Computation of Reference Currents

This subsection deals with computation of reference currents for the control of single-phase GCI. The schematic of proposed control algorithm is depicted in Fig.5.5. The

control scheme offers simultaneous power quality ancillary services and the reference power injection.

$$i_{vsi}(P_{ref}) = \frac{2 \times P_{ref}}{V_{mf}^2} \times v_{pccf}$$

where V_{mf} is the amplitude of v_{pccf} .

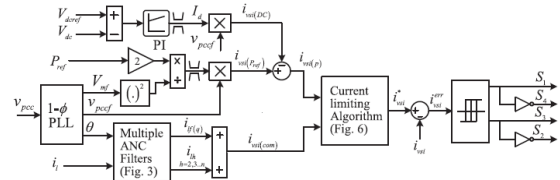

Fig.6 Block diagram of the proposed multiple ANC-filters-based control scheme.

V.SIMULATION RESULTS

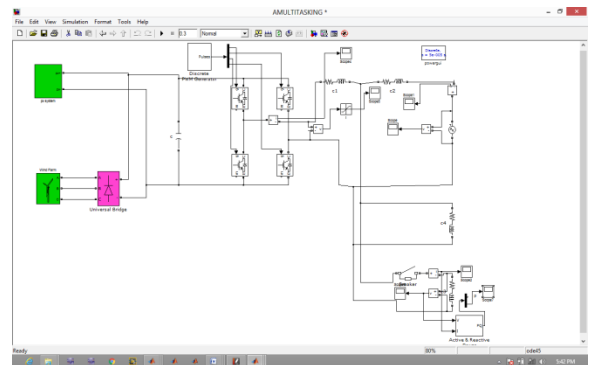

Fig.7 MATLAB/SIMULINK diagram of proposed system

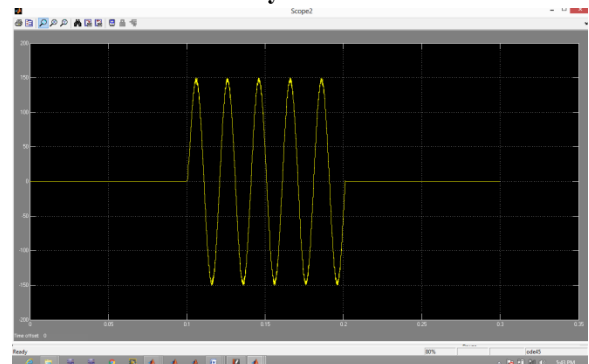

Fig.8 single ANC load voltage

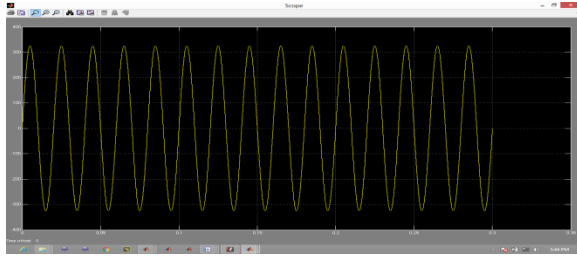

Fig.9 grid voltage

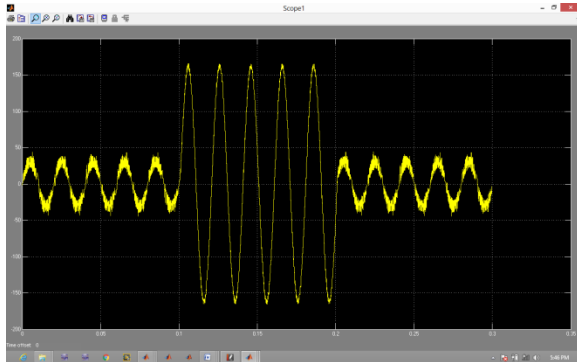

Fig.10 multiple ANC load voltage

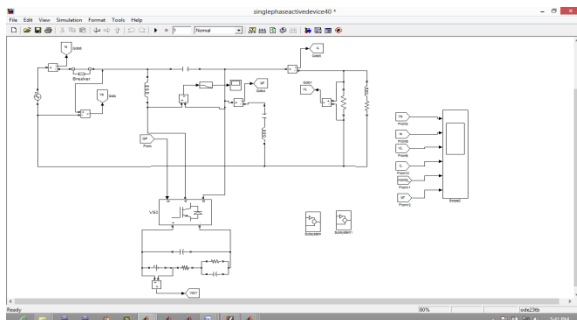

Fig.11 single phase active device

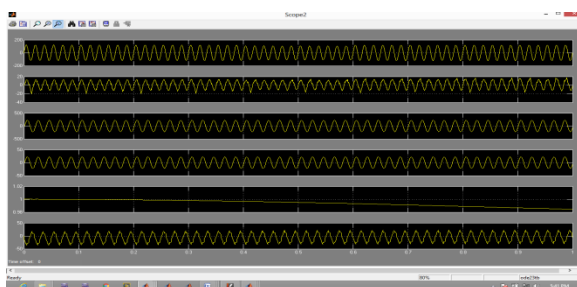

Fig.12 Performance during reference power change.

V.CONCLUSION

A single-phase H-bridge voltage supply inverter is utilized as a vigor digital interface between the Distribution Generation (DG) procedure and the grid. This proposed algorithm employs a current decomposition constitution headquartered on more than one adaptive interference offset filters for pulling of sympathetic and acute currents of the topical anesthetic hundreds. A single-phase phase-locked loop utilizing Adaptive interference offset filters has been modernized to synchronize the GCI at primary frequency. Based on the analytics of the results and the excellent harmonic decomposition capabilities, it is evident that the intended manipulate algorithm is a good alternative to existing FFT, MSOGI and NN-based methods. A simple and effective current confining algorithm has also been proposed, discussed and implemented to limit the GCI current.

REFERENCES

- [1] G. M. Masters, *Renewable and Efficient Electric Power Systems*. Hoboken, NJ, USA: Wiley, 2004.
- [2] M. Monfared and S. Golestan, "Control strategies for single-phase grid integration of small-scale renewable energy sources: A review," *Int. J. Renew. Sustain. Energy Rev.*, vol. 16, no. 7, pp. 4982–4993, Sep. 2012.
- [3] L. An, Y. Chen, Z. Shuai, and C. Tu, "An improved reactive current detection and power control method for single-phase photovoltaic gridconnected DG system," *IEEE Trans. Energy Convers.*, vol. 28, no. 4, pp. 823–831, Dec. 2013.
- [4] N. Saadat, S. S. Choi, and D. M. Vilathgamuwa, "A series-connected photovoltaic distributed generator capable of enhancing power quality," *IEEE Trans. Energy Convers.*, vol. 28, no. 4, pp. 1026–1035, Dec. 2013.
- [5] Z. Zeng, H. Yang, R. Zhao, and C. Cheng, "Topologies and control strategies of multi-functional grid-connected inverters for power quality



enhancement: A comprehensive review," *Int. J. Renew. Sustain. Energy Rev.*, vol. 24, pp. 223–270, Sep. 2013.

[6] A. Elrayyah, A. Safayet, Y. Sozer, I. Husain, and M. Elbuluk, "Efficient harmonic and phase estimator for single-phase grid-connected renewable energy systems," *IEEE Trans. Ind. Appl.*, vol. 50, no. 1, pp. 620–630, Jan. 2014.

[7] Y. Yang and F. Blaabjerg, "Synchronization in single-phase grid-connected photovoltaic systems under grid faults," in *Proc. 3rd IEEE Int. Symp. Power Electron. Distrib. Gener. Syst.*, Jun. 2012, pp. 476–482.

[8] M. H. Bollen, *Understanding Power Quality Problems*. Piscataway, NJ, USA: IEEE Press, 2000.