

## DESIGN AND CFD ANALYSIS OF DIFFERENT PIPE JOINTS USED IN WATER SUPPLY INDUSTRIES

**M. Venkateswararao**

Student - M. Tech  
(CAD/CAM), Mechanical  
Engineering Dept., Pragathi  
Engineering college, AP,  
INDIA

**Dr P. Kumar Babu**

Professor, Mechanical  
Engineering Department,  
Pragathi Engineering  
college, AP, INDIA

**S. Srikanth**

Assistant Professor,  
Mechanical Engineering  
Department, Pragathi  
Engineering college, A P ,  
INDIA

### ABSTRACT

*Pipe Distribution network system is very common in industries such as water supply industry, nuclear power plant industry, chemical industry, water treatments plants etc, where the fluid or gases to be transported from one location to other location. The pressure loss may vary depending on the type of components used in the total network, material of the pipe, the fluid that is being transported through the network and pipe fitting. The analysis of pipe network is very important in engineering point of view. A lot of engineering problem dealt with it.. Fittings are used in pipe and plumbing systems to connect straight pipe or tubing sections, to adapt to different sizes or shapes, and for other purposes, such as regulating or measuring fluid flow. Most commonly used fitting or joints in industries are Elbow joint, T-joint and straight joint .One problem facing today's water supply industries are flow-accelerated corrosion and erosion in pipe joints. The model geometry of three different pipe joints i.e. Elbow, T section and straight joints are created by using solidworks 2016 software and the simulations are being performed using the ANSYS CFD FLUENT module after mesh were created using the ANSYS software. This report documents the results of the simulations that have been made to date; baseline results employing the RNG  $k-\epsilon$  turbulence model are presented. Pressure, velocity, shear stress on wall, turbulent kinetic energy inner surface of elbow joint , straight joint & T - joint are shown in figures, and there values are noted and tabulated.. Plots of the velocities, pressure field, wall shear stress, and turbulent kinetic energy adjacent to the wall are shown within the three different joints section.*

**Keywords:** ANSYS CFD FLUENT, ANSYS Software, Pipe.

### 1. INTRODUCTION:

The **water Industry** provides drinking water and waste water services (including sewage treatment) to residential, commercial, and industrial sectors of the economy, its total distribution system depends on piping and pipe fitting. The pipes are used for transporting various fluids like water, steam, different type of gases, oil and other chemical with or without pressure from one place to another place. The pipe material used in pipe network system depending on the application. Cast iron, wrought iron, steel, and brass are the material generally used for pipes in engineering practice. The fluid to be conveyed in pipes whose temperature to be varied but the annual average temperature is 35 °C while the relative humidity varies generally from 70% during the day to 90% at night. The temperature of potable water to be conveyed in the pipelines will be about 30° C. The pipes used in petroleum industry are generally seamless pipes made of heat resistance chrome molybdenum alloy steel. Such type of pipe can resist pressure more than 4Nmm<sup>2</sup> and temperatures greater than 440.c.

The pipes for a particular use cannot be made of desired length. Therefore pipes of standard length are taken and joined

together with the help of different pipe joints. Pipes and pipeline components, including their protective coatings and joint materials, that will or may come into contact with potable water shall not constitute a toxic hazard; shall not support microbial growth; shall not cause taste or odour, cloudiness or discoloration of the water. There are different shape and materials to be used for conveying fluid material. The joints are used in piping system are one of the parts of pipe which are used for changing direction the fluid flow in distribution system.

A **fitting** is used in pipe systems to connect straight pipe or tubing sections, adapt to different sizes or shapes and for other purposes, such as regulating (or measuring) fluid flow. "Plumbing" is generally used to describe the conveyance of water, gas, or liquid waste in domestic or commercial environments;

piping is often used to describe the high-performance (high-pressure, high-flow, high-temperature or hazardous-material) conveyance of fluids in specialized applications. Tubing is sometimes used for lighter-weight piping, especially that flexible enough to be supplied in coiled form.

## 2. Materials:

The material with which a pipe is manufactured is often the basis for choosing a pipe. Materials used for manufacturing pipes include:

- Carbon (CS) and galvanized steel
- Impact-tested carbon steel (ITCS)
- Low-temperature carbon steel (LTCS)
- Stainless steel(SS)
- Malleable iron

- Non-ferrous metals (includes copper, inconel, incoloy and cupronickel)
- Non-metallic(includes acrylonitrile butadiene styrene (ABS), fibre-reinforced plastic (FRP), polyvinyl chloride (PVC), high-density polyethylene(HDPE) and toughened glass)
- Chrome-molybdenum (alloy) steel — Generally used for high-temperature service

The bodies of fittings for pipe and tubing are most often the same base material as the pipe or tubing connected: copper, steel, PVC, chlorinatedpolyvinylchloride (CPVC ) or ABS. Any material permitted by the plumbing, health, or building code (as applicable) may be used, but it must be compatible with the other materials in the system, the fluids being transported and the temperature and pressure inside (and outside) the system. Brass or bronze fittings are common in copper piping and plumbing systems. Fire hazards, earthquake resistance and other factors also influence the choice of fitting materials.

## 3. SOLID WORKS

By using solid works three model of pipe joints are Generated

### Elbow Joint

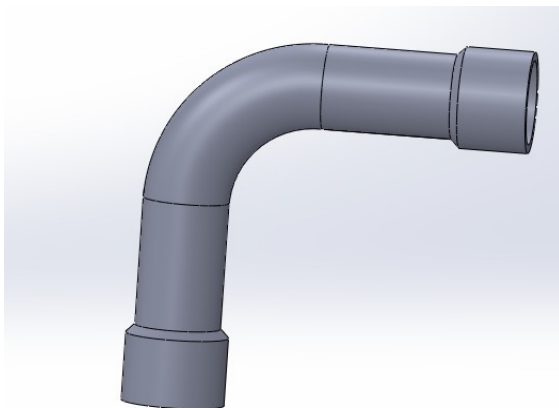
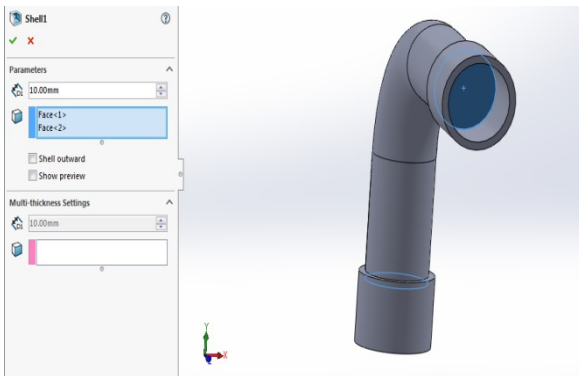
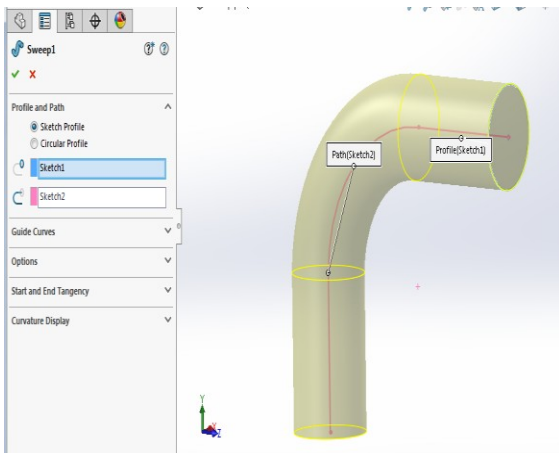
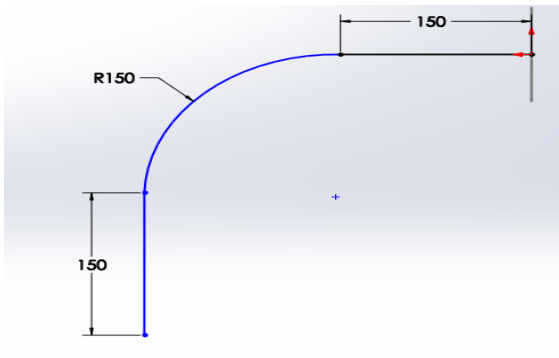

### T Joint

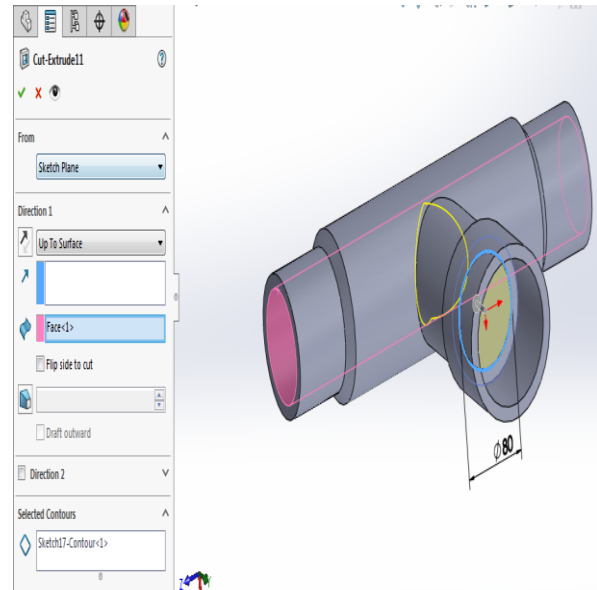

### Straight Joint

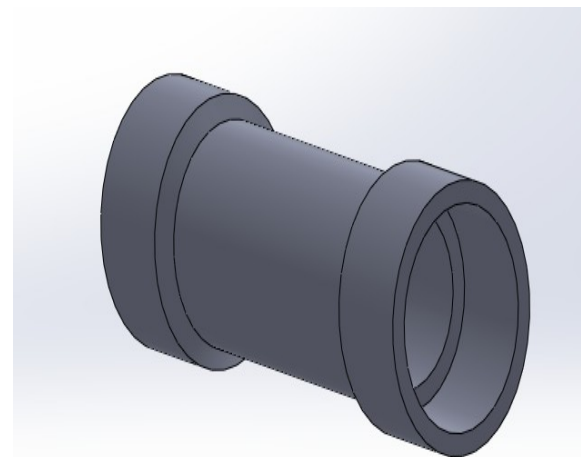

### 4. ANALYSIS

Computational fluid dynamic analysis is performed on elbow pipe, T-joint, straight joint by using FLUENT module in ansys software. Boundary conditions such as inlet velocity wall conditions flow types etc applied on model.

Pressure, velocity, shear stress on wall and turbulent kinetic energy inside of Different joints of pipes are finding out.

**Mesh**

**Name selection**

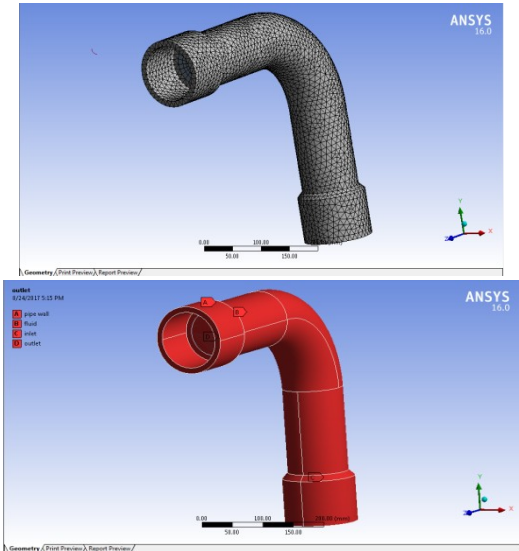

**Set up**

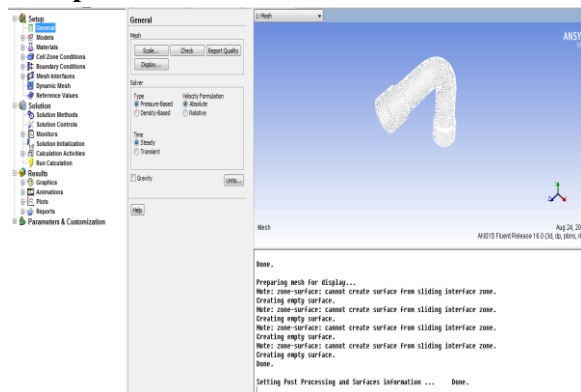

**Pressure Velocity**

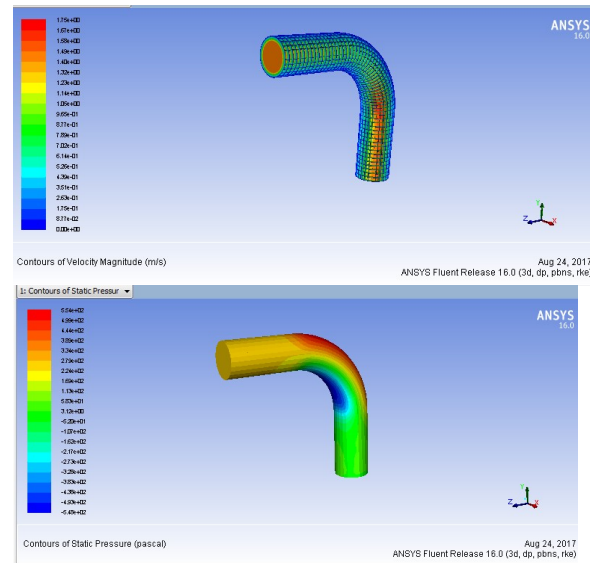

**Turbulence kinetic energy shear stress**

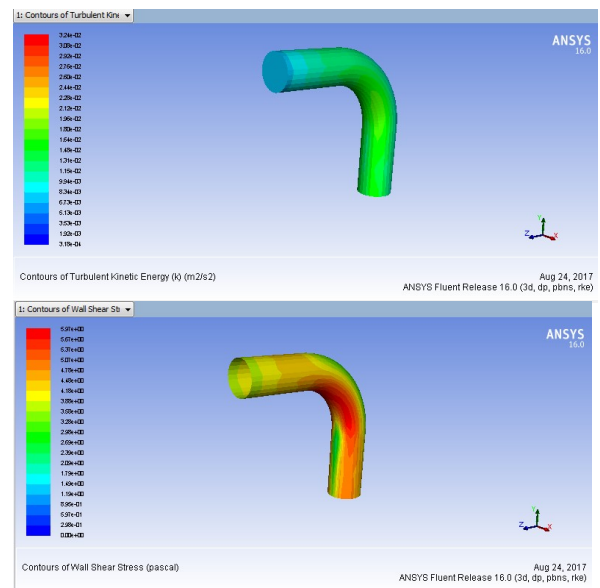

**For straight joint: Mesh Name selection**

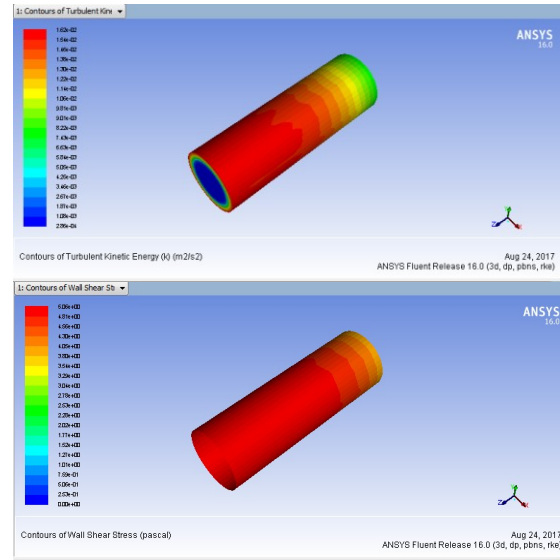
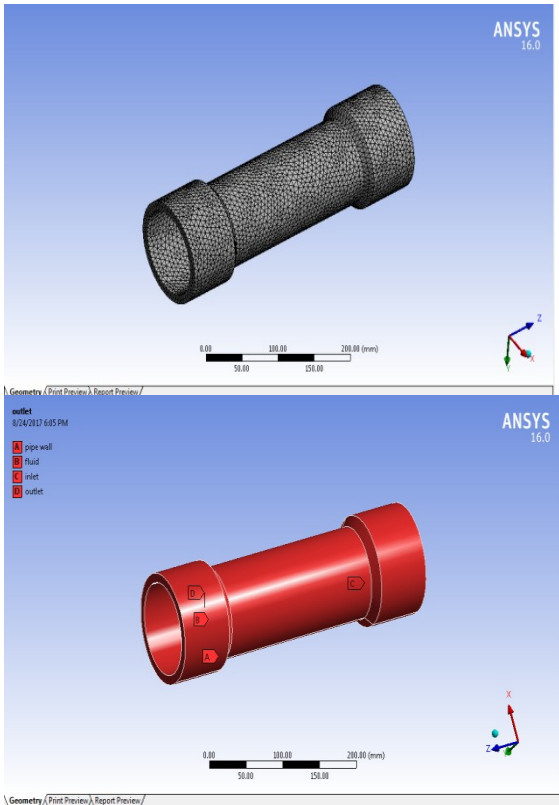

**Pressure velocity**

**For T joint:**

**Mesh Name selection**

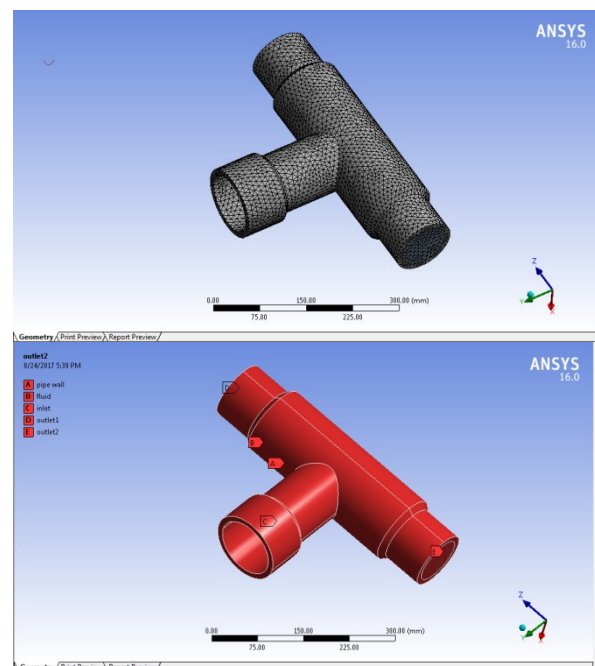
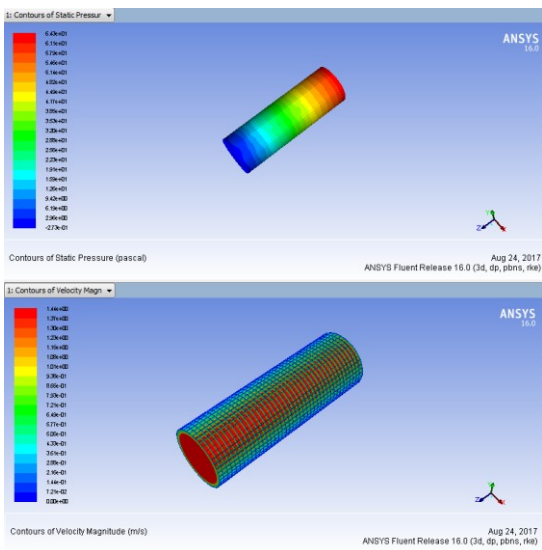

**Turbulence kinetic energy  
 shear stress**

### Pressure velocity

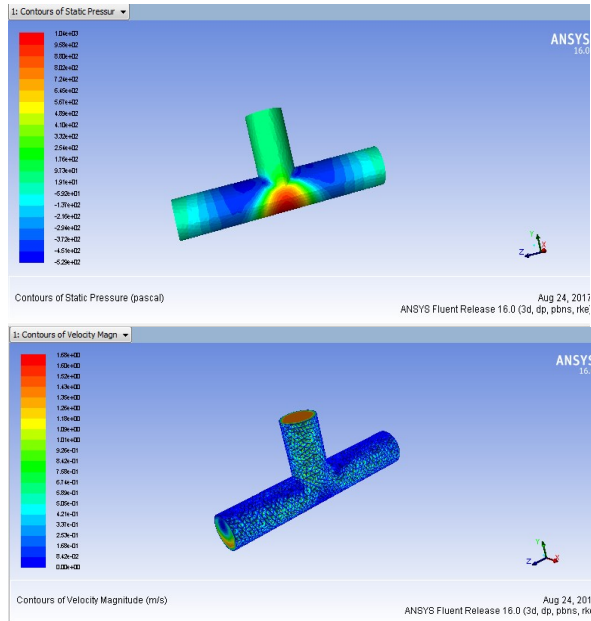

### Turbulence kinetic energy shear stress

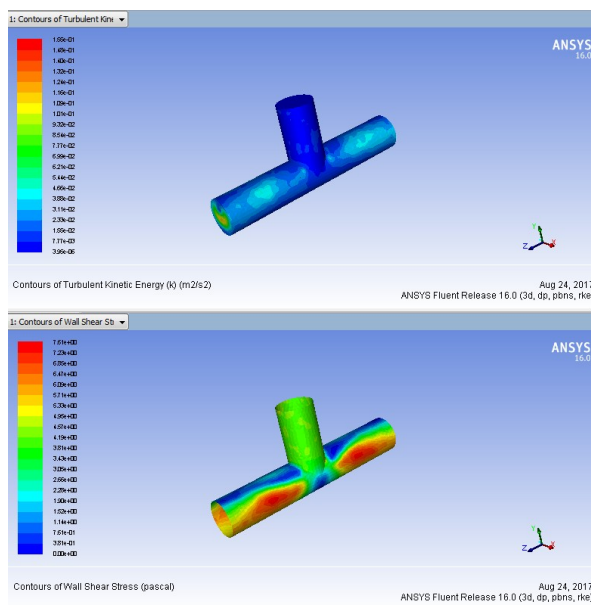

**Result:** pressure, velocity, turbulence kinetic energy ,shear stress of various pipe joints are calculated

### CONCLUSION

- Brief study about elbow joint, T-joint, straight joint its applications and importance in industrial purpose is studied in this project
- 3d model of elbow pipe, T-joint, straight joints are generated by using Solid works 2016 software.
- Generated 3d models is transfer to the Ansys workbench 16 software for analysis by converting it to a neutral file IGES.
- Computational fluid dynamic analysis is performed on elbow pipe T-joint, and straight joint by using FLUENT module in ansys software.
- Boundary conditions such as inlet velocity wall conditions flow types etc applied on model.
- Pressure, velocity, shear stress on the wall and turbulent kinetic energy inside of a pipe joints are got as result after solve.
- Counters of Pressure, velocity, shear stress on wall, turbulent kinetic energy inner surface of elbow joint , straight joint & T - joint are shown in figures, and there values are noted and tabulated.
- Thus the CFD ANALYSIS of three pipe joints are done and there results are studied

### REFERENCES

[1] CFD Simulation and Analysis of Fluid Flow Parameters within a Y-Shaped Branched Pipe IOSR Journal of Mechanical and Civil Engineering (IOSR-JMCE) Aslam A. Hirani1, C. Udaya Kiran2

[2] FLOW DISTRIBUTION NETWORK ANALYSIS FOR DISCHARGE SIDE OF CENTRIFUGAL PUMP



By Satish M. Rajmane Research Scholar, WIT  
Research Center, Solapur University, Sholapur,  
India Dr. S. P. Kallurkar Principal, Atharva  
College of Engineering, Mumbai, India

[3] Fluid Mechanics And Hydraulic Machines  
BY DR.BANSAL

[4] CFD Analysis of the Effect of Elbow Radius  
on Pressure Drop in Multiphase Flow by Quamrul  
H. Mazumder.

[5] COMPARATIVE ANALYSIS IN PIPE  
DESIGN BY ANALYTICAL AND GRAPHICAL  
METHODS FOR SELECTION OF MATERIALS

International Journal of Innovative Research in  
Science, Engineering and Technology

ISSN: 2319-8753

[6] Reliability and failure pressure prediction of  
various grades of pipeline steel in the presence of  
corrosion defects and pre-strain  
L.Y.Xu..Y.F.Cheng

[7] Petro Wiki PRODUCT ANALYSIS AND  
STRESS ANALYSIS OF PROCESS PIPING  
ROUTING BY USING CAESAR II

ISSN 2278 – 0149, www.ijmerr.com, , April 2015

[9] Pipe line Risk Management Manual: Ideas,  
Techniques, and Resources By W. Kent Muhlbauer

[10] NPTEL: Mechanical Engineering - Fluid  
Mechanics

[11] Geometric Modeling Based on Polygonal  
Meshes Mario Botsch<sup>1</sup> Mark Pauly<sup>1</sup> Leif Kobbelt  
<sup>2</sup> Pierre Alliez <sup>3</sup> Bruno L'evy <sup>4</sup> Stephan Bischoff <sup>2</sup>  
Christian Ross<sup>1,3</sup>