

INTELLIGENT ENERGY MANAGEMENT OF A BIPV BUILDING

Y. Vijay jawahar paul,

Assistant Professor,
Department Of EEE

Christu Jyothi Institute of Technology
&Science, Colombo Nagar, Telangana

N.Raju,

Assistant Professor,
Department Of EEE

Christu Jyothi Institute of Technology
&Science, Colombo Nagar, Telangana

K.Prasada Rao,

Assistant Professor,
Department Of EEE

Christu Jyothi Institute of Technology
&Science, Colombo Nagar, Telangana

M.Vishal

Student

Department Of EEE

Christu Jyothi Institute Of Technology &
Science, Colombo Nagar, Telangana.

Abstract

This project primarily focuses on creating a model for a Battery Management Unit (BMU) designed for a standalone off-grid solar photovoltaic (PV) system, with the goal of implementing this model using the MATLAB software tool. In any independent system, having a secondary energy storage device like a battery is crucial to provide backup power. For this study, we have chosen to model a Lithium-ion (Li-ion) battery due to its favorable characteristics, including efficient charge and discharge performance, high power density, compact size, and low maintenance requirements. Ensuring the safe and reliable operation of such batteries is essential, achieved through close monitoring and control of their State of Charge (SOC). SOC determination is critical as it allows us to gauge the remaining energy stored in the battery, facilitating its discharge based on the system's energy demands. The primary components of this project include modeling the PV energy source, implementing Maximum Power Point Tracking (MPPT), regulating the DC output using a boost converter, employing an inverter, and managing the energy flow between the PV source, battery, load, and vice versa.

1. Introduction

The rise in the global population has led to an increased demand for electrical power. To meet this escalating demand, fossil fuels were predominantly used,

which unfortunately resulted in pollution. Consequently, addressing the growing power requirements can be achieved through the utilization of renewable energy sources [1]-[3]. Among these, solar photovoltaic cells show great promise and are attracting significant attention. However, the power generation from these sources is intermittent, dependent on varying climatic conditions. Therefore, in small-scale independent renewable energy systems, energy storage is imperative to enhance response time and power availability. The primary challenge in implementing this technology arises from the unreliable nature of conventional power grids [4]. Various methods have been explored to enhance the efficiency of electrical power grids using renewable sources [5].

The inconsistency in solar radiation necessitates the use of tracking systems to optimize power harvesting from PV systems, ensuring their reliable operation. Consequently, a charge control system becomes crucial for maximizing power

capture under varying irradiation conditions. This is essential for both battery management and load regulation [6]. This project encompasses the monitoring of AC and DC loads in PV-based autonomous systems. Such systems require a secondary energy source like a battery to supply power during periods of limited sunlight. Therefore, to regulate battery power, buck-boost converters play a pivotal role. Additionally, inverters are integrated into the autonomous system to provide power to AC loads. Hence, ensuring reliable power supply to all loads within the system involves effective coordination between converters and inverters [7], [8].

2. System Configuration and Modeling

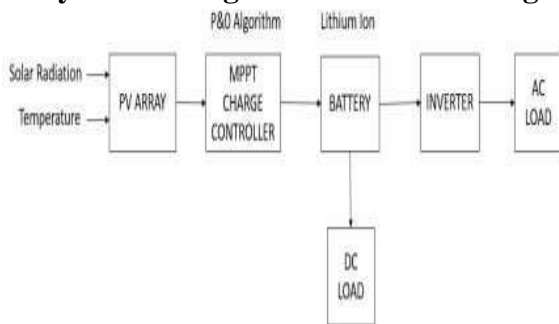

Figure 1.Block Diagram of Battery Management for Solar PV standalone System

The standard setup commonly used in traditional solar Photovoltaic energy conversion systems (PVECS) is illustrated in Figure 1. This setup comprises a solar PV energy source, a converter unit for regulating DC power, an MPPT (Maximum Power Point Tracking) system for optimizing power harvest, and essential loads. The converter on the generation side is controlled using signals from the MPPT system, and there's

another converter on the grid or load side. The loads within the system can be categorized into DC and AC loads. A significant portion of these loads can effectively operate on DC power. However, certain essential loads, which require high power, rely on AC power. Therefore, in an autonomous system, even when both the generated and standby power sources are in DC, it is essential to include an inverter to provide power to these crucial AC loads [9]. This approach holds particular importance for autonomous systems that involve a combination of DC and AC loads. Proper coordination between these two types of loads, taking into consideration available power, backup sources, and load priorities, is crucial [10].

Regarding the PV Array, a solar cell is a component that converts radiant energy from light into electrical energy. Within these cells, the energy from radiation stimulates the emission of electrons, leading to the generation of DC current. Solar cells in an electrical system or module are responsible for capturing radiation and converting it into electricity. Electrical system arrays consist of multiple panels connected either in series or parallel, depending on the specific requirements of the system [11].

Table 1.Parameter Specification ofPV Module

Parameters	Specification
Output power	12.07 w
Maximum Power point Current & Voltage	7A & 1.8 v
Short circuit current and Open circuit voltage	8A & 21 v

Battery Design

Batteries Batteries play a crucial role in providing backup power for various appliances. They are devices primarily responsible for converting chemical energy into useful electrical energy. A typical battery is composed of cells and modules, and the rating of each cell is determined by its intended application. In autonomous systems, the primary function of batteries is to store the power generated from the source and release this stored energy when required. Lithium-ion batteries are gaining increasing attention in photovoltaic-based autonomous systems [12].

Given the significance of batteries, it is equally important to monitor them effectively. This monitoring process ensures the reliable and safe operation of the battery, allowing the autonomous system to deploy a control mechanism for activating and deactivating the battery's energy output based on specific requirements. Monitoring systems that oversee the charge and discharge power of batteries are invaluable in this regard. These systems enable the autonomous system to implement a control strategy, switching the battery on or off as needed. Critical battery parameters are considered during the control operation, further ensuring the battery's safety [13]-[14].

Table2. Parameter Specification of Battery

Parameters	Specification
Battery Type	Lithium-ion
Nominal Voltage	24v
Initial State of Charge	50%
Ampere hour rating	14Ah
Fully Charged	28v

Voltage	
---------	--

Initial state of charge (SOC) is set at 50%, following the standard manufacturer specifications for newly purchased batteries that retain a charge of 50% or higher. In practical applications, the SOC is not permitted to exceed 50%, so the battery is recharged when the SOC reaches this threshold.

Figure 2 illustrates the approach taken in the battery charge control system. The primary goal of this control system, implemented for managing batteries, is to continuously monitor the terminal voltage and charge status. During the initial assessment, if the battery's charge level is at its maximum, such as 100%, the battery is instructed to remain in a floating state [15]. Conversely, if the battery's charge falls below the expected value, the control system directs the battery to charge either in constant voltage or current mode. When the battery's voltage drops below a stable voltage level [16], this condition is utilized to estimate the Maximum Power Point Tracking (MPPT) charging position

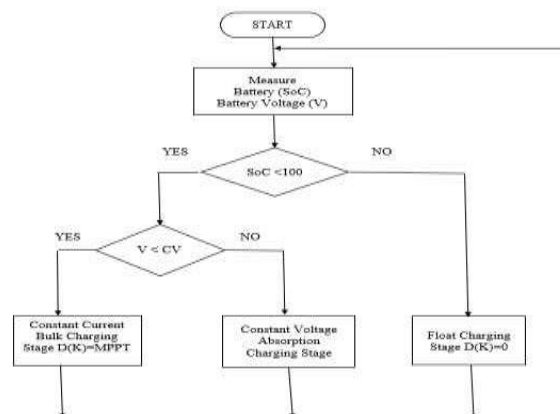

Figure 2.Flowchart of a three-stage lithium-ion battery charge controller

3.MPPT Control

Typically, a solar cell can convert only about 30-40% of the total incident solar irradiation into electricity. To enhance the efficiency of a specific solar cell, Most Maximum Power Point Tracking (MPPT) technology is employed. MPPT is a technique utilized to extract the maximum available energy from a photovoltaic (PV) system under specific conditions. The maximum energy a PV system can generate depends on factors such as irradiation and other ambient conditions. Generally, a PV module produces its maximum power voltage at a cell temperature of 25°C, but this voltage can fluctuate with changes in external temperature. MPPT monitors the output of a specific PV panel and adjusts the battery voltage to achieve the most efficient voltage, known as the maximum power point [17].

The underlying principle of a power tracking system involves adjusting the resistance appropriately while sampling the output of a PV cell to obtain maximum power. MPPT performs best in cooler conditions because PV modules operate more effectively at lower temperatures. It is also highly effective when the battery is deeply discharged since it can extract more current under low charge conditions [18]. MPPT devices are integrated with power electronics, forming an electrical power converter system in the form of solar inverters that convert DC power into AC power.

In this standalone system, the Perturb and

Observe method is utilized, which relies on monitoring panel voltage and current to perform calculations. Solar battery voltage is periodically adjusted either upward or downward to track the maximum power point. In this approach, a voltage sensor is used exclusively to measure the photovoltaic array voltage.

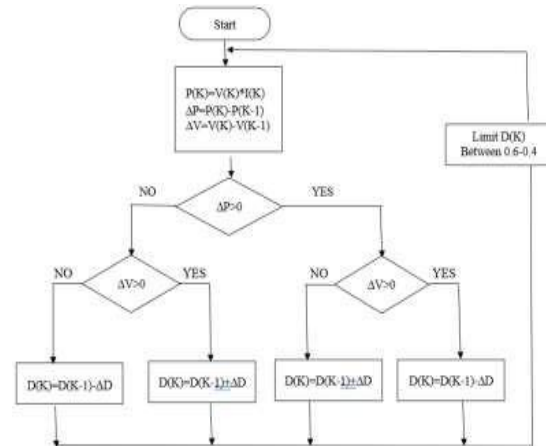

Figure 3.P & O MPPT Scheme

Figure 3 illustrates the implementation of the Perturb and Observe (P&O) Maximum Power Point Tracking (MPPT) scheme, with clear labeling of each block's functions. The P&O MPPT algorithm takes input from the voltage and current readings of the PV array. A unit delay is employed to handle the previous trial (K-1) function. The condition switch block manages the three if-else conditions within the P&O algorithm, while the D block handles the perturbation phase size for the duty cycle. The task cycle increment and decrement function is governed by a feedback loop denoted as D(K-1), which includes an adder and a memory block.

To prevent the duty cycle from approaching 0.4 or 0.6 too closely, a limiting unit, D(K), is in place. The

controller's output in the form of a duty cycle is linked as one of the inputs to the battery unit's charge controller, while the other input is the power associated with the PV. This setup is crucial for estimating the converter's efficiency.

Boost Converter Design

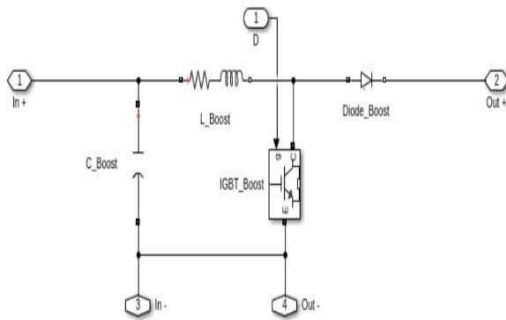

Figure 4.Circuit Diagram of DC-to-DC Converter (BOOST) used in simulation

Various types of converters can be employed as controllers to adjust the unregulated DC voltage, transforming it into the required value suitable for the system's specific conditions. Each regulating converter system requires a method for switching devices on and off based on operational needs. The choice of devices, such as IGBT or MOSFET, depends on the system's requirements and constraints. In this study, IGBT has been selected to drive the converter components used in the system, and an appropriate driving system has been implemented for this purpose [19].

Figure 4 depicts the configuration of the converter circuit considered in this study. The key components of this setup include a load resistor, capacitor, inductor, diode, and switches. To control the switches effectively, a form of driving scheme is

necessary, which has been achieved by employing a Pulse Width Modulation (PWM) scheme for switching. This is crucial for regulating the designed voltage. This arrangement connects the PV system with the storage battery and the required load. The role of the control system employed for the converter is to manage the switches of the converter, turning them on or off as needed to maintain the output voltage at the desired level. The diode in the system assists in aligning the output according to the switch conditions. This, in turn, ensures that the inductor and capacitor supply the necessary power to the load.

4. Result and Discussion

Subsystem of Solar PV with battery storage

Usually solar array utilizes 30-40% of the incident solar radiation to produce electricity. To get betterment in energy generation, power tracking scheme is essential. It is utilized by matching required source impedance and load impedance. Within the source side a lift converter is linked with solar array to reinforce the require voltage at the output. The source impedance gets matched with load impedance by appropriately changing the operating cycle of switches used in the converter.

Output DC Power

Figure 6 is the output voltage, current and power waveform obtained from MATLAB simulation for two different level irradiance (1000w/m², 600w/m²) and constant temperature (25 °C)

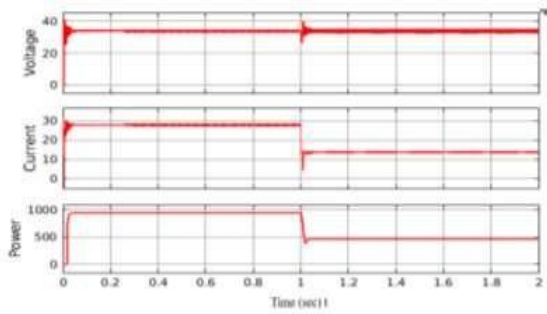

Figure 6.Output result of solar PV

It is observed that with decrease in incident irradiation at $t=1\text{sec}$, the number of charge carriers produced decreases, so the current falls drastically. This results in decrease in the power harnessed from the solar PV modules. The voltage however is subject to small fluctuations but remains almost constant because the number of charge carriers determine the amount of current through the load, but the potential difference depends on the electric field between the solar cell p-n junction.

Output of Battery

The Figure 7 shows that the output voltage of battery across the time (1s) starts decreasing and remains at 25.6v. Hence, it is observed that output of battery terminal voltage increases with increase in irradiation.

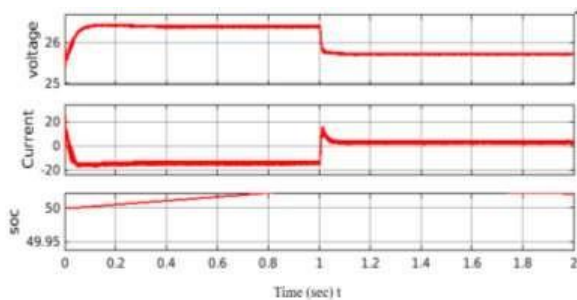

Figure 7.Output of Battery

Output Voltage of DC Load

The DC power obtained from the panel is fed to inverter for converting into ac power for feeding ac load which is output voltage of single-phase resistive load shown in Figure 8.

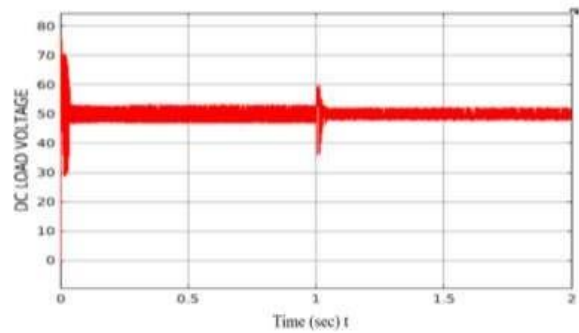

Figure 8.DC Voltage across Load

Output Current of DC Load

The DC power obtained from the panel is fed to inverter for converting into ac power for feeding ac load which is output current of single-phase resistive load shown in Figure 9.

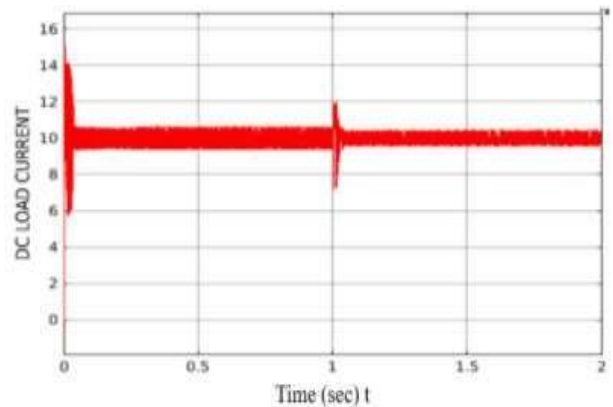

Figure 9.DC Current across Load

The DC load voltage and current waveforms are almost constant with minor ripples within the standard error limits. Change in illumination at $t=1\text{sec}$ causes a spike in both voltage and current waveforms, however the boost converter stabilizes and compensates for the

changes to retain the output constant.

5. Conclusion

The model presented is designed and simulated using MATLAB. A 1KW photovoltaic standalone system has been developed using MATLAB Simulink. This model is framed around required tracking for utmost utilization of energy. The MPPT is governed by the P & O algorithm, and the output results of voltage, current and power waveforms across various units are presented with respect to time. The algorithms improve the dynamics and steady state performance of the photovoltaic system. This further improves the efficiency of the DC-DC converter system. The proposed system also stabilizes the terminal voltage of the battery used in the system for changing irradiation. The State of Charge (SOC) of the battery is monitored for efficient utilization of remaining energy in the battery, as the discharging takes place based on system requirements. In this scenario, the performance of the Lithium-ion battery offered a good charge and discharge profile with high power density meeting the requirements of the system in an efficient manner.

References

- [1] GShafiee, Q., Dragicevic, T., Vasquez, J.C. 2014 Hierarchical control for multiple DC microgrids clusters Int. Multi-Conference on Systems Signals & Devices (SSD14), pp. 922– 933.
- [2] Seyed Mahdi Ashabani and Yasser Abdelrady I. Mohamed 2014 New Family of Microgrid Control and Management Strategies in Smart Distribution Grids Analysis Comparison and Testing in IEEE Transactions on Power Systems Vol. 29 No. 5.
- [3] F. Chen, R. Burgos, D. Boroyevich, J. C. Vasquez, & J. M. Guerrero 2019 Investigation of nonlinear droop control in dc power distribution systems are Load sharing, voltage regulation, efficiency, and stability, IEEE Trans. on PE.
- [4] P. Suhane, S. Rangnekar, A. Mittal and A. Khare 2016 Sizing and performance analysis of standalone wind- photovoltaic based hybrid energy system using ant colony optimization IET Renewable Power Generation vol. 10 no. 7 pp. 964-972.
- [5] Dragi cevi, Lu, Vasquez, & Guerrero 2016 DC microgrid A review of control strategies and stabilization techniques IEEE Trans. on Power electronics.
- [6] Olivares, Mehrizi Sani, Etemadi 2014 Trends in microgrid control IEEE Trans. Smart Grid 5 (4) pp. 1905–1919.
- [7] Lopez-Vargas, A., Fuentes, M., Vivar, M., & Munoz-Rodriguez, F. J. 2019 Low-cost data logger intended for remote monitoring of solar photovoltaic stand-alone systems based on ArduinoTM IEEE Sensors Journal.
- [8] Nasir, Anees, Khan, Xu, & Guerrero 2019 Integration and decentralized Control of Standalone Solar Home Systems for offgrid Community Applications IEEE Trans. on Industry App.
- [9] Koad, Zobia, ElShahat, 2017 A Novel MPPT algorithm based on particle swarm optimization for photovoltaic systems IEEE Trans. Sustain. Energy.
- [10] Jain, K., Bhargava, A., & Mewara, B. 2018 Power Quality Enhancement Using Unified Power Flow Controller in Standalone Grid Connected Solar PV System International Conference on Inventive Research in Computing Applications (ICIRCA).
- [11] G Sivasankar, K Vidhyaa, E Anitha, B Ashok Kumar, P Vairaprakash, 2016 Application of Luo converter and multilevel cascaded converter for grid integration of solar pv systems International Conference on Circuit, Power and Computing Technologies (ICCPCT)

- [12] Hong, J., Yin, J, Liu, Y., Peng, J., & Jiang, H. 2019 *Energy Management and Control Strategy of Photovoltaic/battery Hybrid Distributed Power Generation Systems with an Integrated Three-port Power Converter IEEE - Energy Management and Control Strategy.*
- [13] Narayanan, V., Kewat, S., & Singh B 2020 *Solar PV-BES Based Microgrid System with Multifunctional VSC IEEE Transactions on Industry Applications.*
- [14] B. S. Shatakshi and S. Mishra 2018 *Dual mode operational control of single stage PVbattery based microgrid Proc. IEEMA Eng. Inf. Conf. pp. 1-5.*
- [15] M. S. Rahman and A. M. T. Oo 2017 *Distributed multi-agent based coordinated power management and control strategy for microgrids with distributed energy resources Energy Conversation and Management vol. 139 pp. 20-32.*
- [16] J. D. Wang and F. Yang, 2013 *Optimal capacity allocation of standalone wind/solar/battery hybrid power system based on improved particle swarm optimization algorithm IET Renewable Power Generation vol. 7 no. 5pp. 443- 448.*
- [17] B. Subudhi and R.Pradhan 2013 *A comparative study on maximum power point tracking techniques for photovoltaic power systems IEEE Trans. Sustainable Energy.*
- [18] M. Hamza, M. Shehroz, S. Fazal, M. Nasir and H. A. Khan 2017 *Design and analysis of solar PV based low Power low Voltage DC microgrid architectures for rural electrification IEEE Power energy Society.*
- [19] M. Nasir, S. Iqbal & H. A. Khan 2018 *Optimal planning and design of low voltage low power solar DC microgrids IEEE Trans. Power System.*
- [20] Bilal Abdul Basit, Abd Ur Rehman, Han Ho Choi, and Jin Woo Jung 2021 *A Robust Iterative Learning Control Technique to Efficiently Mitigate Disturbances for 3 Phase Standalone Inverters IEEE Power System.*
- [21] B Ashok Kumar, M Srinivasa Venkatesh, G Mohan Muralikrishna 2015 *Optimization of photovoltaic power using PID MPPT controller based on incremental conductance algorithm Power Electronics and Renewable Energy Systems Springer.*