

## SMART WATERING SYSTEM

**N.Siva kumar,**  
Assistant Professor  
Department Of ECE

CVRT Engineering college, Tadipatri.

**K.Veneela Rani**  
Assistant Professor  
Department Of ECE

CVRT Engineering college, Tadipatri.

### ABSTRACT:

*Water is one of the essential parts of life. Water pollution is one of the big problems to the world. In order to ensure the safe supply of the drinking and useful water for different purposes like agricultural, the water should be monitored. This paper presents a design of a low cost system for real time monitoring of the water. This paper presents an IoT device which helps to manage and plan the usage of water. This system can be easily installed and maintained for long run. The level sensor is placed on the tank which continuously monitors the water level in real time. Whenever the person reach water dispenced automatically. This information will be updated in the cloud and user can analyze the amount of water.*

### I.INTRODUCTION OF PROJECT

Water is one of the most important basic needs for all living beings, but unfortunately, a huge amount of water is being wasted because of uncontrolled use and exploitation of water resource. Kerala averages rainfall of 3,000 mm a year. The general impression was that among all the states in India, Kerala had ample drinking water, but it's not the case. There are 1,164 problem villages without the adequate supply of drinking water. Even though Kerala has 44 rivers spanning its lush green landscape. Together, they contribute an annual discharge of 72, 00 million cubic meters of water which is unused to the Arabian Sea. One of the main reasons for the shortage is poor management of water. Overflowing water tanks in residence, schools, colleges, Municipal overhead tanks, Hospitals etc. can contribute to the massive amount of water wastage. If we can control this we can save large amounts of water. Conventional water tanks can neither monitor nor control the water level in the tank. As of now, the water level has to be manually checked and refilled according to the requirements.

### II.LITERATURE SURVEY

In the studies from [1] the author proposed that an IoT based water monitoring system that measures water level in real-time. The model is based on idea that the water level can be very important parameter when it comes to the flood occurrences especially in disaster prone areas. A water level sensor is used to detect the desired parameter, and if the water level reaches the parameter, the signal will be feed in real time to social network like Twitter.

In the [2] the author proposed that in recent times, tremendous growth of Internet of Things applications is seen in smart homes. The large variety of various IoT applications generally leads to interoperability requirements that need to be fulfilled. Current IoT project is achieved using physical platforms that lack intelligence on decision making. A architecture that implement Event-Condition-Action (ECA) method is proposed to solve the management of heterogeneous IoTs in smart homes. The proactive architecture, developed with a core repository stores persistent data of IoTs schema, proved to be an ideal solution in solving interoperability in smart homes.

In [3] the paper proposed that drinking water the quality needs to be monitor in real time. In this paper we present a design and development of a low cost system for real time monitoring of the water quality in IoT (internet of things). The system comprises of many sensors is used to measuring physical and chemical parameters of the water.

In [4] the author shown how to monitor the water level of water systems such as water tanks, rivers, ground water table, and bore wells remotely. They also shown that how to control the working of pump automatically and remotely. It can be

used to remotely monitor the flood affected areas wirelessly and information can be sent to mobile wirelessly. This system is designed to monitor the level of water with the help of water level sensors.

### III. DESIGN OF HARDWARE

This chapter briefly explains about the Hardware. It discusses the circuit diagram of each module in detail.

#### ARDUINO UNO

The Arduino Uno is a microcontroller board based on the ATmega328 (datasheet). It has 14 digital input/output pins (of which 6 can be used as PWM outputs), 6 analog inputs, a 16 MHz ceramic resonator, a USB connection, a power jack, an ICSP header, and a reset button. It contains everything needed to support the microcontroller; simply connect it to a computer with a USB cable or power it with a AC-to-DC adapter or battery to get started.

The Uno differs from all preceding boards in that it does not use the FTDI USB-to-serial driver chip. Instead, it features the Atmega16U2 (Atmega8U2 up to version R2) programmed as a USB-to-serial converter. Uno board has a resistor pulling the 8U2 HWB line to ground, making it easier to put into DFU mode. Arduino board has the following new features:

- 1.0 pin out: added SDA and SCL pins that are near to the AREF pin and two other new pins placed near to the RESET pin, the IOREF that allow the shields to adapt to the voltage provided from the board. In future, shields will be compatible both with the board that use the AVR, which operate with 5V and with the Arduino Due that operate with 3.3V. The second one is a not connected pin, that is reserved for future purposes.
- Stronger RESET circuit.
- Atmega 16U2 replace the 8U2.

"Uno" means one in Italian and is named to mark the upcoming release of Arduino 1.0. The Uno and version 1.0 will be the reference versions of Arduino, moving forward. The Uno is the latest in a series of USB Arduino boards, and the reference model for the Arduino platform; for a comparison with previous versions, see the index of Arduino boards.

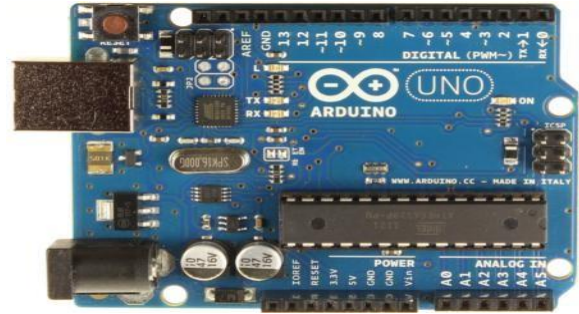

**Fig: ARDUINO UNO POWER SUPPLY:**

The power supplies are designed to convert high voltage AC mains electricity to a suitable low voltage supply for electronic circuits and other devices. A power supply can be broken down into a series of blocks, each of which performs a particular function. A d.c power supply which maintains the output voltage constant irrespective of a.c mains fluctuations or load variations is known as "Regulated D.C Power Supply".

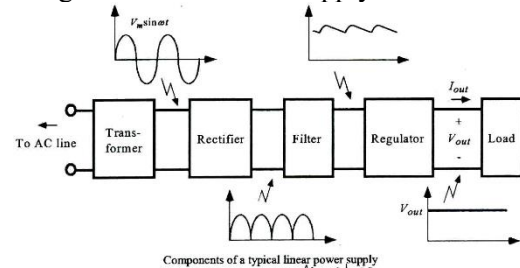

**Fig: Block Diagram of Power Supply**

#### LCD DISPLAY

A model described here is for its low price and great possibilities most frequently used in practice. It is based on the HD44780 microcontroller (Hitachi) and can display messages in two lines with 16 characters each. It displays all the alphabets, Greek letters, punctuation marks, mathematical symbols etc. In addition, it is possible to display symbols that user makes up on its own. Automatic shifting message on display (shift left and right), appearance of the pointer, backlight etc. are considered as useful characteristics.



**Fig: LCD**

**BUZZER**

Digital systems and microcontroller pins lack sufficient current to drive the circuits like relays, buzzer circuits etc. While these circuits require around 10milli amps to be operated, the microcontroller's pin can provide a maximum of 1-2milli amps current. For this reason, a driver such as a power transistor is placed in between the microcontroller and the buzzer circuit.

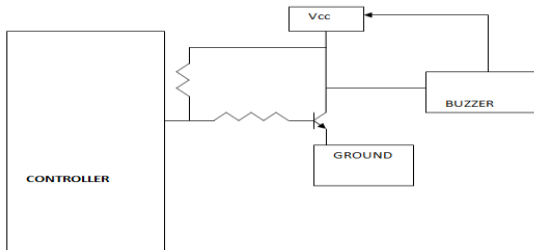

**WIFI MODULE:**

The **ESP8266** is a low-cost Wi-Fi microchip with full TCP/IP stack and microcontroller capability produced by Shanghai-based Chinese manufacturer, Espressif Systems.<sup>[1]</sup>

The chip first came to the attention of western makers in August 2014 with the **ESP-01** module, made by a third-party manufacturer, Ai-Thinker. This small module allows microcontrollers to connect to a Wi-Fi network and make simple TCP/IP connections using Hayes-style commands. However, at the time there was almost no English-language documentation on the chip and the commands it accepted.<sup>[2]</sup> The very low price and the fact that there were very few external components on the module which suggested that it could eventually be very inexpensive in volume, attracted many hackers to explore the module, chip, and the software on it, as well as to translate the Chinese documentation.<sup>[3]</sup>

The **ESP8285** is an ESP8266 with 1 MiB of built-in flash, allowing for single-chip devices capable of connecting to Wi-Fi.<sup>[4]</sup> The successor to these microcontroller chips is the ESP32.

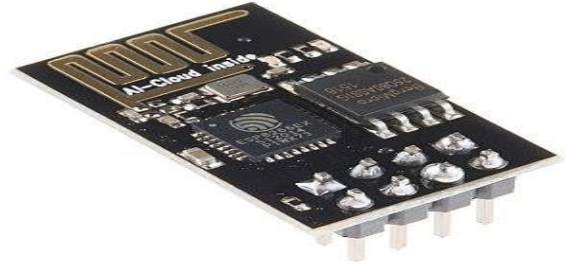

**RELAY**

**BASIC RELAY SWITCH**

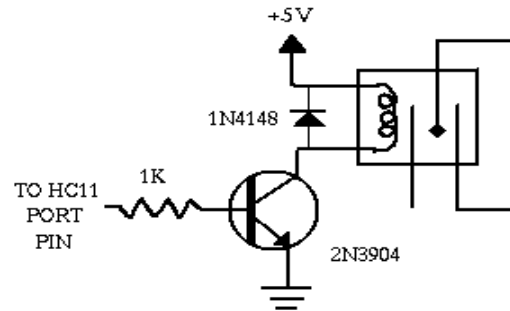

The following schematic shows the basic circuit. A relay is an electrically operated switch. When you turn it on, it switches on way. When it is off, it switches the other way. You can use a relay to switch on and off a high current device. A relay has an electromagnet, called a coil, and a lightweight switch inside it. When you energize the coil, a piece of the switch is attracted by the coil's magnetic field, which switches the switch on or off.

**Mechanical relay:**

**Water Level Indicator:**

This is the circuit diagram of a simple corrosion free water level indicator for home and industries. In fact, the level of any conductive non-corrosive liquids can be measured using this circuit. The circuit is based on 5 transistor switches. Each transistor is switched on to drive the corresponding LED when its base is supplied with current through the water through the electrode probes.

One electrode probe is (F) with 6V AC is placed at the bottom of the tank. Other probes are placed step by step above the bottom probe. When water is rising the base of each transistor gets electrical connection to 6V AC through water and the corresponding probe. This, in turn, makes the transistors conduct to glow LED and indicate the level of water. The ends of probes of the water tank level indicator are connected to corresponding points in the circuit as shown in circuit diagram.

Insulated Aluminum wires with end insulation removed will do for the probe. Arrange the probes in order on a PVC pipe according to the depth and immerse it in the tank. AC voltage is used to prevent electrolysis at the probes. So, this setup will last really long. I guarantee at least 2 years of maintenance-free operation. That's what I got and is still going.

### Mini Submersible Pump

Submersible pumps in general are designed to be fully submerged into the water. Submersible pumps are placed within the reservoir of water that requires pumping out, which is why they are normally used for drainage in floods, sewerage pumping, emptying ponds or even as pond filters. In this article, the mechanism of a smaller type of submersible water pump called the mini submersible pump will be specifically addressed. A mini submersible pump is a smaller version of the submersible water pumps which is lightweight, small size, low consumption, and makes little noise. A mini submersible water pump is used widely in household for cooking, cleaning, bathing, space heating, watering flowers, etc. A mini submersible water pump is a centrifugal water pump, which means that it uses a motor to power an impeller that is designed to rotate and push water outwards. The motor is located in a waterproof seal and closely connected to the body of the water pump which it powers. Filtration pumps found inside aquarium fish tanks utilize a type of mini submersible water pump. The mini submersible water pump is installed inside the actual fish tank to pump the water out where it is needed.



### IV. BLOCK DIAGRAM:

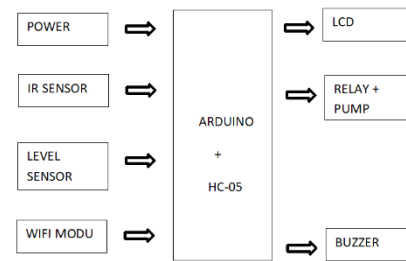

### V. CONCLUSION

In this paper, a prototype water monitoring system using IoT is presented. For this some sensors are used. The collected data from the all the sensors are used for analysis purpose for better solution of water problems. The data is sends to the cloud server via Wi-Fi module ESP8266. So this application will be the best challenger in real time monitoring & control system and use to solve all the water related problems.

### REFERENCES:

[1] Thinakaran Perumal, Imd Nasir Sulaiman, 2Leong.C.Y, "Internet of Things (IoT) Enabled Water Monitoring System ",2015 IEEE 4th Global Conference on Consumer Electronics (GCCE)  
[2] Perumal, T.; Sulaiman, M.N.; Mustapha, N.; Shahi, A.; Thinaharan, R., "Proactive architecture for Internet of Things (IoT)s management in smart homes," Consumer Electronics (GCCE), 2014 IEEE 3rd Global Conference on, pp.16,17, 7-10 Oct. 2014.  
[3] N Vijaykumar ,R Ramyas, "The real time monitoring of water quality in IOT environment",IEEE sponsored 2nd international conference on innovations in information, embedded and communication systems (Iciiecs)2015



[4] Saima Maqbool , Nidhi Chandra, "Real Time Wireless Monitoring and Control of Water Systems using Zigbee 802.15.4" 5th International Conference on Computational Intelligence and Communication Networks., 2013

[5] Prachet Varma, Akshay Kumar, Nihesh Rathod, Pratik Jain, Mallikarjun S, Renu Subramaniyam, Bhardhwaj Amrutur, M.S. Mohan kumar, Rajesh Sundresan, IoT based water management System for a Campus IEEE, IEEE First International Smart Cities Conference (ISC2), 2015

[6] Asaad Ahmed Mohammedahmed Eltaieb, Zhang Jian Min, "Automatic Water Level Control System", International Journal of Science and Research (IJSR) 2013

[7] In 2013, Raghavendra. R, M. Uttara Kumari, S.A. Hariprasad presented a paper on "Implementation of Simulated Water Level Controller", International Journal of Advanced Research in Computer Science and Software Engineering